

BLOCKINDEX - RAHMENGRUPPE

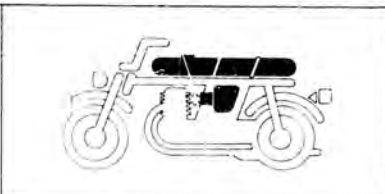
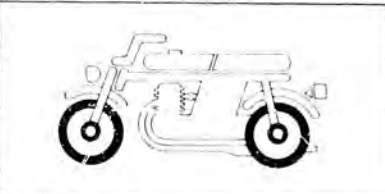
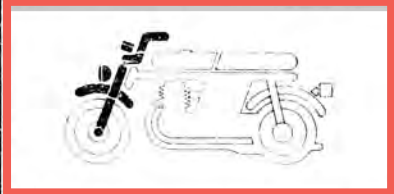

F 1	Scheinwerfer	G 2
F 2	Messer	G 6
F 3	Voltmeter Quarzröhre	H 2
F 3	Lenksägenpedale/Schalter Kabel	H 3
F 4	Vorderbremse-Hauptzylinder	H 7
F 5	Leuchte Oberer Bremsleuchte	H14
F 6	Steigkopfschutz	I 2
F 7	Vorderer Kotflügel	I 5
F 8	Vorderradgabel	I 8

F 9	Vorderradbremssattel	J 2
F 10	Vorderrad	J11
F 11	Hinterradbremse-Hauptzylinder	K 2
F 12	Hinterradbremssattel	K 5
F 13	Hinterrad	K11

F 14	Benzintank	L 4
F 15	Sitz	L10
F 16	Seitendeckel Zündeinheit Regler	L13
F 17	Batterie	M 7
F 18	Luftfilter	M 9

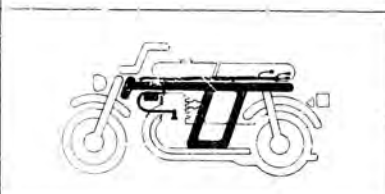
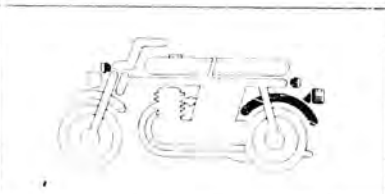

F 19	Ausgleichsopf	M13
F 20	Bremse (als -Schaltpedal)	N 2
F 21	Tritt	N 4
F 22	Ständer	N14
F 23	Hinterer Schwinge - Kettenanschlag	N16
F 24	Hinterer Stoßdämpfer	2-C 5

F 25	Hinterer Kotflügel	2-C 8
F 26	Blinker	2-C10
F 27	Rockerschwert	2-D 5

F 28	Kabelbaum - Zündspule	2-D 7
F 29	Rehnen	2-D10
F 30	Werkzeug	2-E 5
F 31	Verkleidung	2-E 7
F 32	Verkleidungstüte	2-E12
F 33	Verkleidungstasche	2-E16
F 34	Benzintank - Streifen	2-F 3
F 35	Merque Verkleidung	2-F 7
F 36	Merque Seiterdeckel	2-F 8
F 37	Seitendeckel Streifen	2-F 9
F 38	Hinterer Verkleidungsstreifen	2-F11
F 39	Fußtabelle	2-F13

G 2

F-1

Headlight

(CB900Fz • FA • Fb • Fc-E,ED,F,G)

Phare

(CB900Fz • FA • Fb • Fc-E,ED,F,G)

Scheinwerfer

(CB900Fz • FA • Fb • Fc-E,ED,F,G)

Faro delantero

(CB900Fz • FA • Fb • Fc-E,ED,F,G)

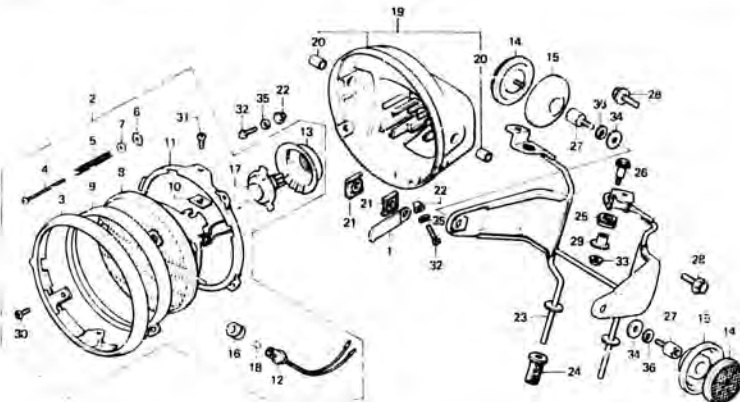

8438-10A

Wartungspunkt	AP	Ref. Nr.	Teile-Nr.	Beschreibung	Menge				Serien-Nr.	Gebiets-Corle
					Fz	Fa	Fb	Fc		
SCHEINWERFER KOMPL. SOCKEL KOMPL., ABSTANDSLICHT + HA. BIRNE	0,1	1	2173-369-000	KLEMME C, KABELBAUM	1	1	1	1		
		2	33100-422-601	SCHEINWERFER KOMPL. (12V 60/55W)	1	1	1	1		E,ED,F,G E
SCHEINWERFEREINHEIT EINSCHL. DAZUGEHÖRIGER TEIL GEHÄUSE, SCHEINWERFER STÜTZE, SCHEINWERFERGEHÄUSE	0,2		33100-422-611	SCHEINWERFER KOMPL. (12V 60/55W)	1	1	1	1		ED,G
			33100-422-621	SCHEINWERFER KOMPL. (12V 60/55W)	1	1	1	1		F
	0,4	3	33101-422-671	ZIERRAHMEN, SCHEINWERFER	1	1	1	1		E,F
	0,6		33101-460-671	ZIERRAHMEN, SCHEINWERFER	1	1			2103511 2103510	ED,G ED,G ED,G
		4	33103-346-670	EINSTELLSCHRAUBE, STRAHL	1	1	1	1		E,ED,F,G
		5	33107-300-003	EINSTELLFEDER, SCHEINWERFER- STRAHL	1	1	1	1		E,ED,F,G
		6	33111-001-023	EINSTELLMÜTTER, SCHEINWERFER- STRAHL	1	1	1	1		E,ED,F,G
		7	33119-371-003	EINSTELLSCHWEIBE, STRAHL	1	1	1	1		E,ED,F,G
		8	33120-371-601	SCHEINWERFEREINHEIT	1	1	1	1		E
			33120-371-611	SCHEINWERFEREINHEIT	1	1	1	1		ED,F,G

G 3

F-1

Headlight

(CB900Fz • FA • FB • Fc-E,ED,F,G)

Phare

(CB900Fz • FA • FB • Fc-E,ED,F,G)

Scheinwerfer

(CB900Fz • FA • FB • Fc-E,ED,F,G)

Faro delantero

(CB900Fz • FA • FB • Fc-E,ED,F,G)

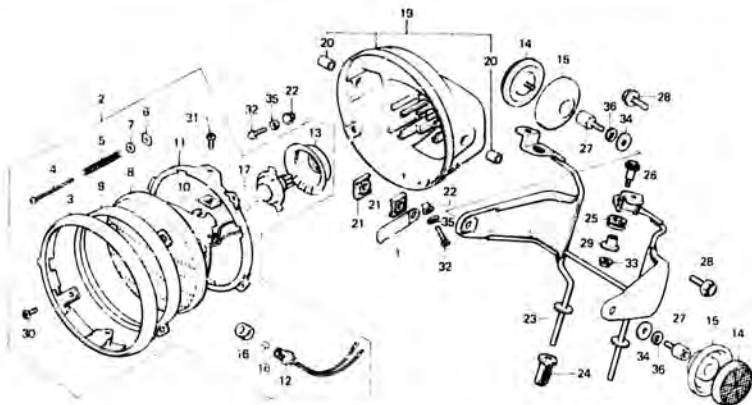

H4.30-1.0a

Wartungspunkt	AP	Ref. Nr.	Teile-Nr.	Beschreibung	Menge				Serien-Nr.	Gebiets-Code
					Fz	FA	Fc	F2c		
		9	33121-405-671	HALTERING	1	1	1			E,ED,F,G
		10	33128-292-670	MUTTER, EINHEITHALTER	2	2	2	2		E,ED,F,G
		11	33153-422-003	BEFESTIGUNGSRING	1	1	1	1		E,ED,F,G
		12	33170-390-611	SCHEDEL KOMPL., ABSTANDSLICHT	1	1	1	1		E,ED,F,G
		15	33180-422-003	GUMMIDECKEL	1	1	1	1		E,ED,F,G
		14	33741-413-003	REFLEKTOR, v. (STANLEY)	2	2	2	2		E,ED,F,G
		15	33743-425-600	BASIS, v. REFLEKTOR	2	2	2	2		E,ED
		16	33905-371-601	GUMMI, VERBINDUNG	1	1	1	1		F,ED,F,G
		27	34901-371-601	H4 BIRNE(12342/99)	1	1	1	1		E,ED,G
			34901-371-621	H4 BIRNE(12342/99) PHILIPS-FABRIKATION	1	1	1	1		F
		18	34903-388-611	BIRNE, POSITIONSLICHT (12V 4W)	1	1	1	1		E,ED,F,G
		19	61301-425-000	GEHAEUSE, SCHEINWERFER (LOCL. PROCUREMENT PART)	1	1	1	1		E,ED,F,G
		20	61302-425-000	MUELSE, SCHEINWERFERGEHAEUSE	2	2	2	2		E,ED,F,G

G 4

F-1

Headlight

(CB900Fz • FA • FB • FC-E,ED,F,G)

Phare

(CB900Fz • FA • FB • FC-E,ED,F,G)

Scheinwerfer

(CB900Fz • FA • FB • FC-E,ED,F,G)

Faro delantero

(CB900Fz • FA • FB • FC-E,ED,F,G)

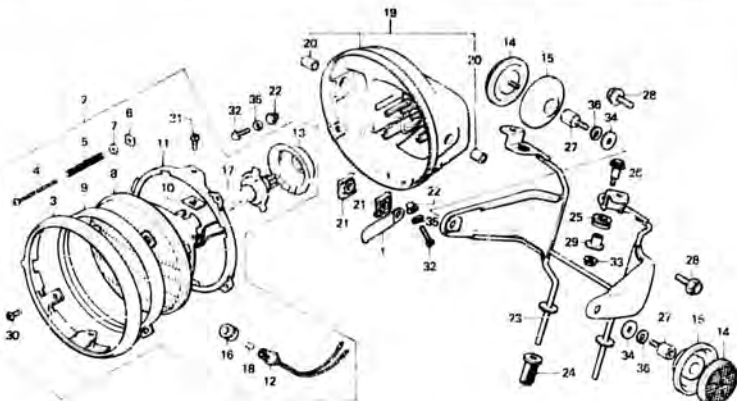

6236-1105

Wartungspunkt	AP	Ref. Nr.	Teil-Nr.	Beschreibung	Menge				Serien-Nr.	Gebiets-Code
					Fz	Fa	Fc	F2c		
		21	61303-423-010	MUTTER, SCHEINWERFERGEHAEUSE	2	2	2	2		E,ED,F,G
		22	61304-292-000	BEFESTIGUNGSMUELSE, SCHEINWERFER	2	2	2	2		E,ED,F,G
		23	61311-432-000	STUETZE, SCHEINWERFERGEHAEUSE	1	1				E,ED,F,G
			61311-436-130	STUETZE, SCHEINWERFER			1			E,ED,F,G
			61311-487-610	STUETZE, SCHEINWERFER				1		E,ED,F,G
		24	61313-438-000	GUMMITUELLE B, SCHEINWERFER	2	2	2	2		E,ED,F,G
		25	61316-438-000	BEFESTIGUNGSGUMMI, SCHEINWERFERSTUETZE	2	2	2	2		E,ED,F,G
		26	90002-438-000	FLANSCHENSCHRAUBE, 6x38	2	2	2	2		E,ED,F,G
		27	90120-425-000	STUETZENSCHRAUBE, SCHEINWERFER	2	2	2	2		E,ED,F,G
		28	90151-422-000	FESTSTELLSCHRAUBE, SCHEINWERFERGEHAEUSE	2	2	2	2		G
		29	90501-438-000	MUELSE, SCHEINWERFERGEHAEUSE	2	2	2	2		F
		30	93500-03008-1A	KEGELKOPFSCHRAUBE, 3x6	2	2	2	2		G
		31	93500-03008-04	KEGELKOPFSCHRAUBE, 5x8	2	2	2	2		E,ED,F,G
		32	93500-03018-08	KEGELKOPFSCHRAUBE, 3x16	2	2	2	2		E,ED,F,G
		33	94050-06000	FLANSCHENMUTTER, 6MM	2	2	2	2		E,ED,F,G

G 5

F-1

Headlight

(CB900Fz • FA • Fb • Fc-E,ED,F,G)

Phare

(CB900Fz • FA • Fb • Fc-E,ED,F,G)

Scheinwerfer

(CB900Fz • FA • Fb • Fc-E,ED,F,G)

Faro delantero

(CB900Fz • FA • Fb • Fc-E,ED,F,G)

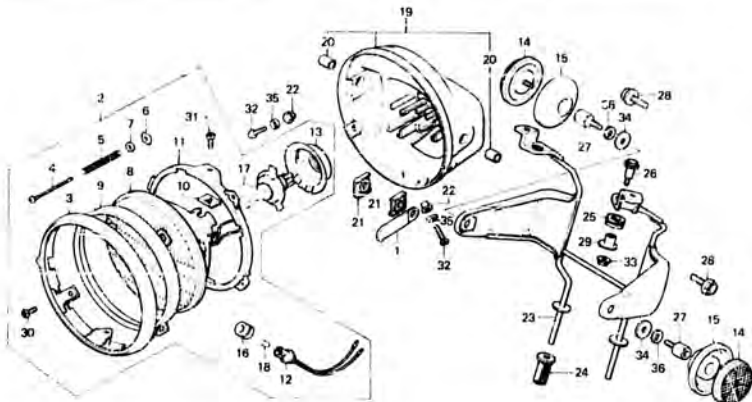

9439-1104

Wartungspunkt	AP	Ref. Nr.	Teile-Nr.	Beschreibung	Menge				Serien-Nr.	Gebiets-Code
					Fz	FA	Fb	Fc F2c		
		34	94101-10000	GLATTE SCHEIBE, 10MM	2	2	2	2		E,ED
		35	94111-05000	FEDERRING, 5MM	2	2	2	3		E,ED,F,G
		36	94111-10000	FEDERRING, 10MM	2	2	2	2		E,ED



F-1-1

Headlight

(CB900Fz • FA • FB • FC-DK,DM,SA,U)

Phare

(CB900Fz • FA • FB • FC-DK,DM,SA,U)

Scheinwerfer

(CB900Fz • FA • FB • FC-DK,DM,SA,U)

Faro delantero

(CB900Fz • FA • FB • FC-DK,DM,SA,U)

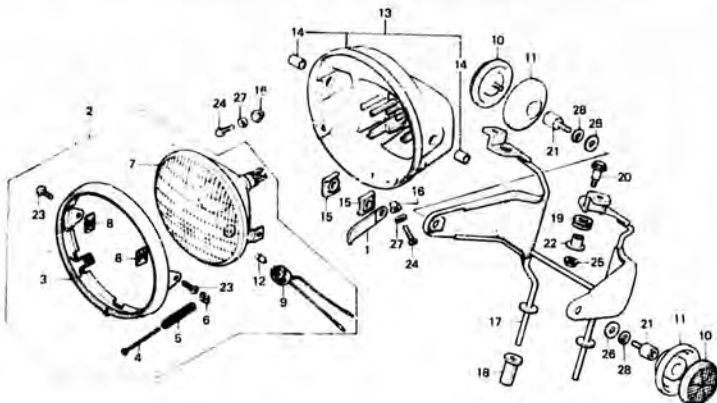

8420-139

Wartungspunkt	AP	Ref. Nr.	Teile-Nr.	Beschreibung	Menge				Serien-Nr.	Gebiets-Code	
					F1	Fa	Fc	F2c			
SCHEINWERFER KOMPL., SOCKEL KOMPL., ABSTANDSLICHT BASIS, V. REFLEKTOR	0,1	1	32173-369-000	KLEHME C, KABELBAUM	1	1	1			DK,DM,SA,U	
		2	33100-422-681	SCHEINWERFER KOMPL.	1	1	1	1			DK,DM,SA,U
ODIE GLEICHE ABSTANDSLICHT- PAUSCHALE, AUCH WENN NUR EIN ODER ALLE TEILE GEWARTET WIRD	0,2	3	33101-422-003	ZIERRAHMEN, SCHEINWERFER (12V 50/40W)	1				2104001	2104000	DK,DM,SA,U DK,DM,SA,U
				33101-460-791	ZIERRAHMEN, SCHEINWERFER	1					
EINSCHL. DAZUGEHÖRIGER TEIL GEHÄUSE, SCHEINWERFER	0,4	4	33103-246-670	EINSTELLSCHRAUBE, STRAHL	1	1	1	1			DK,DM,SA,U
STÜTZLE, SCHEINWERFERGEHÄUSE	0,6	5	33107-300-003	EINSTELLFEDEP, SCHEINWERFER- STRAHL	1	1	1	1			DK,DM,SA,U
		6	33117-001-023	EINSTELLMUTTER, SCHEINWERFER- STRAHL	1	1	1	1			DK,DM,SA,U
		7	33120-375-003	SCHEINWERFEREINHEIT	1	1	1	1			DK,DM,SA,U
		8	33128-292-670	MÜTTER, EINHEITALTER	2	2	2	2			DK,DM,SA,U
		9	33170-323-003	SOCKEL KOMPL., ABSTANDSLICHT	1	1	1	1			DK,DM,SA,U
		10	33741-413-003	REFLEKTOR, V. (STANLEY)	2	2	2	2			DK,DM,SA,U
		11	33743-425-600	BASIS, V. REFLEKTOR	2	2	2	2			DK,DM,SA,U

G 7

F-1-1

Headlight

(CB900Fz · FA · FB · FC-DK,DM,SA,U)

Pharo

(CB900Fz · FA · FB · FC-DK,DM,SA,U)

Scheinwerfer

(CB900Fz · FA · FB · FC-DK,DM,SA,U)

Faro delantero

(CB900Fz · FA · FB · FC-DK,DM,SA,U)

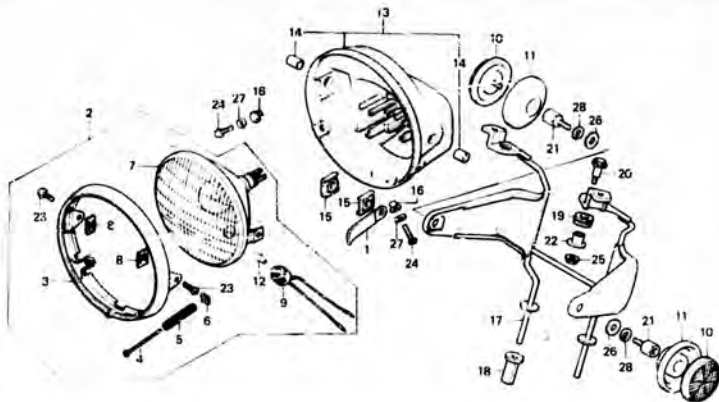

0430-118

Wartungspunkt	AP	Ref. Nr.	Teile-Nr.	Beschreibung	Menge				Serien-Nr.	Gebiets-Code
					Fz	Fa	Fc	FzC		
		12	34903-071-003	BIRNE, ABSTANDSLICHT (12V 3,4W) (STANLEY)	1	1	1	1		DK,DM,SA,U
		13	61301-423-000	GEHAEUSE, SCHEINWERFER	1	1	1	1		DK,DM,SA,U
		14	61302-423-000	HUELSE, SCHEINWERFERGEHAEUSE	2	2	2	2		DK,DM,SA,U
		15	61303-423-010	MUTTER, SCHEINWERFERGEHAEUSE	2	2	2	2		DK,DM,SA,U
		16	61304-292-000	BEFESTIGUNGSHUELSE, SCHEINWERFER	2	2	2	2		DK,DM,SA,U
		17	61311-438-000	STUETZE, SCHEINWERFERGEHAEUSE	1	1				DK,DM,SA,U
			61311-438-730	STUETZE, SCHEINWERFER			1			DK,DM,SA,U
			61311-MB7-610	STUETZE, SCHEINWERFER				1		DK,DM,SA,U
		18	61312-438-000	GUMMITUELLE B, SCHEINWERFER	2	2	2	2		DK,DM,SA,U
		19	61316-438-000	BEFESTIGUNGSGUMMI, SCHEINWERFERSTUETZE	2	2	2	2		DK,DM,SA,U
		20	90007-438-000	FLANSCHENSCHRAUBE, 6X38	2	2	2	2		DK,DM,SA,U
		21	90120-423-000	STUETZENSCHRAUBE, SCHEINWERFER	2	2	2	2		DK,DM,SA,U
		22	90501-438-000	HUELSE, 6X14,8	2	2	2	2		DK,DM,SA,U
		23	93500-03008-0H	KEGELKOPFSCHRAUBE, 5x8	2	2	2	2		DK,DM,SA,U
		24	93500-05016-0B	KEGELKOPFSCHRAUBE, 5x16	2	2	2	2		DK,DM,SA,U
		25	94050-06000	FLANSCHENMUTTER, 6MM	2	2	2	2		DK,DM,SA,U

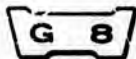

F-1-1

Headlight

(CB900Fz • FA • Fb • Fc-DK,DM,SA,U)

Phare

(CB900Fz • FA • Fb • Fc-DK,DM,SA,U)

Scheinwerfer

(CB900Fz • FA • Fb • Fc-DK,DM,SA,U)

Faro delantero

(CB900Fz • FA • Fb • Fc-DK,DM,SA,U)

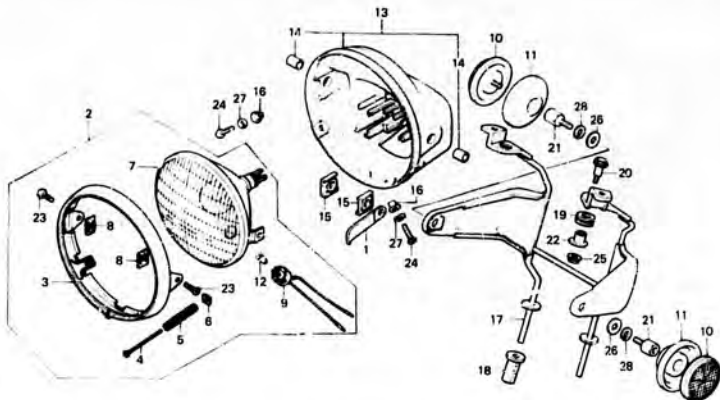

B436-11B

Wartungspunkt	AP	Ref. Nr.	Teile-Nr.	Beschreibung	Menge				Serien-Nr.	Gebiets-Code
					Fz	FA	Fb	Fc		
		26	94101-10000	GLATTE SCHEIBE, 10MM	2	2	2	2		
		27	94111-05000	FEDERRING, 5MM	2	2	2	2		DK,DM,SA,U
		27	94111-10000	FEDERRING, 10MM	2	2	2	2		DK,DM,SA,U



F-1-2

Headlight

(CB900F2s • F2c-E,ED,F,G,U)

Phare

(CB900F2s • F2c-E,ED,F,G,U)

Scheinwerfer

(CB900F2s • F2c-E,ED,F,G,U)

Faro delantero

(CB900F2s • F2c-E,ED,F,G,U)

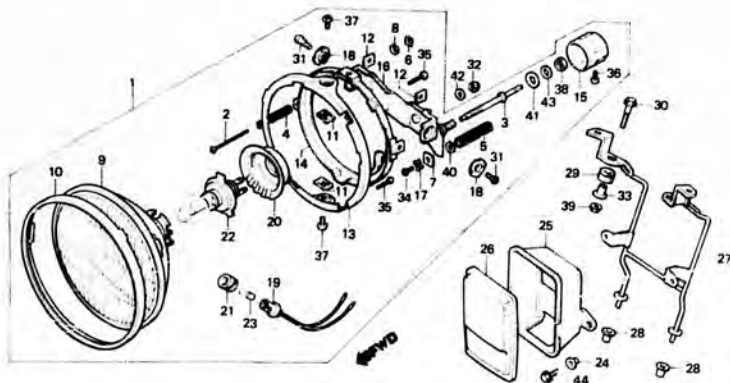

B438-E2B

Wartungspunkt	AP	Ref. Nr.	Teile-Nr.	Beschreibung	Menge				Serien-Nr.	Gebiets-Code
					Fz	Fa	F2c	Fc F2c		
SCHEINWERFER KOMPL.	0.2	1	33100-438-841	SCHEINWERFER KOMPL.	1	1			E,U	
HA BIRNE			33100-438-851	SCHEINWERFER KOMPL.	1	1			ED,G	
SCHEINWERFEREINHEIT	0.3	2	33100-438-951	SCHEINWERFER KOMPL.	1	1			F	
EINSCHL. DAZUGEHÖRIGER TEIL		3	33103-346-670	EINSTELLSCHRAUBE, STRAHL	1	1			E,ED,F,G,U	
HALTER, KOPPLER		3	33103-438-841	EINSTELLSCHRAUBE, STRAHL	1	1			E,ED,F,G,U	
BEFESTIGUNGSRING B	0.4	4	33107-300-003	EINSTELLFEDER, SCHEINWERFER-	1	1			E,ED,F,G,U	
BEUGEL SCHEINWERFER				STRAHL						
FESTSTELLSTUETZE, MESSER	0.5	5	33107-438-841	EINSTELLFEDER, SCHEINWERFER-	1	1			E,ED,F,G,U	
				STRAHL						
		6	33117-001-029	EINSTELLMUTTER, SCHEINWERFER-	1	1			E,ED,F,G,U	
				STRAHL						
		7	33117-438-841	EINSTELLMUTTER, STRAHL	1	1			E,ED,F,G,U	
		8	33119-371-003	EINSTELLSCHRAUBE, STRAHL	1	1			E,ED,F,G,U	
		9	33120-371-601	SCHEINWERFEREINHEIT	1	1			E,U	
			33120-371-611	SCHEINWERFEREINHEIT	1	1			ED,F,G	
		10	33121-463-771	HALTERUNG	1	1			E,ED,F,G,U	

G 10

F-1-2

Headlight
(CB900F2s • F2c-E,ED,F,G,U)

Phare
(CB900F2s • F2c-E,ED F,G,U)

Scheinwerfer
(CB900F2s • F2c-E,ED,F,G,U)

Faro delantero
(CB900F2s • F2c-E,ED,F,G,U)

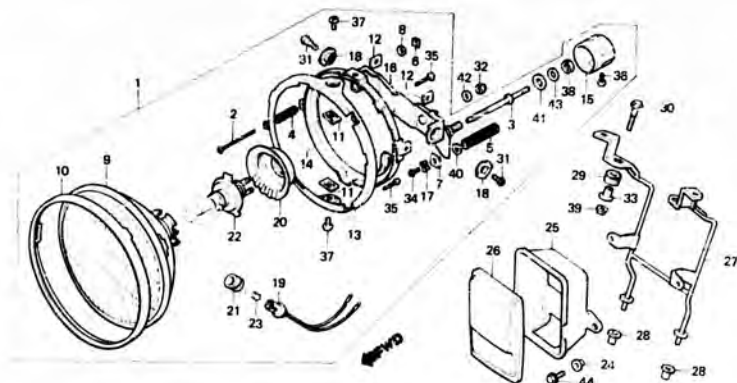

1/4 91-01/B

Wartungspunkt	AP	Ref. Nr.	Teile-Nr.	Beschreibung	Menge			Serien-Nr.	Gebiets-Code
					Fz	Fa	Fc		
		11	33128-292-670	MUTTER, EINHEITHALTER		2	2		E,ED,F,G,U
		12	33128-438-841	MUTTER, EINHEITHALTER		2	2		E,ED,F,G,U
		13	33153-463-771	BEFESTIGUNGSRING A		1	1		E,ED,F,G,U
		14	33154-438-841	BEFESTIGUNGSRING B		1	1		E,ED,F,G,U
		15	33155-463-771	EINSTELCKNOPF, STRAHL		1	1		E,ED,F,G,U
		16	33156-438-841	BUGEL, SCHEINWERFER		1	1		E,ED,F,G,U
		17	33157-463-771	FEDERRING		1	1		E,ED,F,G,U
		18	33165-463-771	SCHEIBE, SCHEINWERFER		2	2		E,ED,F,G,U
		19	33170-390-611	SOCKEL KOMPL., ABSTANDSLICHT		1	1		E,ED,F,G,U
		20	33180-422-003	GUMMIDECKEL		1	1		E,ED,F,G,U
		21	33905-371-501	GUMMI, VERBINDUNG		1	1		E,ED,F,G,U
		22	34901-371-601	H4 BIRNE(12342/99) PHILIPS-FABRIKATION		1	1		E,ED,G,U
			34901-371-621	H4 BIRNE(12342/99) PHILIPS-FABRIKATION		1	1		F
		23	34903-388-611	BIRNE, POSITIONSLICHT (12V 4W) (LOCAL PROCUREMENT PART)		1	1		E,ED,F,G,U

G 11

F-1-2

Headlight
(CB900F2s - F2c-E,ED,F,G,U)

Phare
(CB900F2s - F2c-E,ED,F,G,U)

Scheinwerfer
(CB900F2s - F2c-E,ED,F,G,U)

Faro delantero
(CB900F2s - F2c-E,ED,F,G,U)

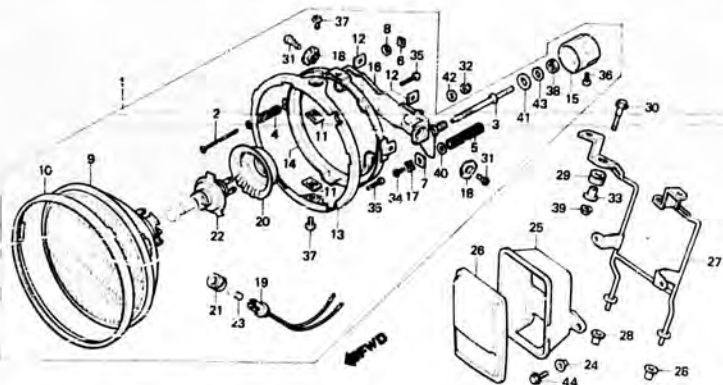

9478-4/28

Wartungspunkt	AP	Ref. Nr.	Teile-Nr.	Beschreibung	Menge				Serien-Nr.	Gebiets-Code
					Fz	Pa	Fm	F2c		
		24	61101-441-000	FESTSTELLHUELSE, V. FENDER			2	2		E,ED,F,G,U
		25	61303-438-850	HALTER, KOPPLER			1	1		E,ED,F,G,U
		26	61306-438-850	DECKEL, HALTER			1	1		E,ED,F,G,U
		27	61311-438-850	FESTSTELLSTUETZE, MESSER			1	1		E,ED,F,G,U
			61311-MB7-710	FESTSTELLSTUETZE, MESSER			1	1		E,ED,F,G,U
		28	61313-422-000	GUMMITUELLE B, SCHEINWERFER			2	2		E,ED,F,G,U
		29	61316-438-000	BEFESTIGUNGSGUMMI, SCHEINWERFERSTUETZE			2	2		E,ED,F,G,U
		30	90002-438-000	FLANSCHENSCHRAUBE, 6x38			2	2		E,ED,F,G,U
		31	90150-463-771	KEGELKOPFSCHRAUBE, 3x10			2	2		E,ED,F,G,U
		32	90301-693-000	MUTTER, DEPFNERSTUEPFE, 5MM			1	1		E,ED,F,G,U
		33	90501-438-000	HUELSE, 6x14, 8			2	2		E,ED,F,G,U
		34	93500-03008-04	KEGELKOPFSCHRAUBE, 3x8			1	1		E,ED,F,G,U
		35	93500-03012-1A	KEGELKOPFSCHRAUBE, 3x12			2	2		E,ED,F,G,U
		36	93500-03014-0G	KEGELKOPFSCHRAUBE, 3x14			1	1		E,ED,F,G,U

G 12

F-1-2

Headlight

(CB900F2a - F2c-E,ED,F,G,U)

Phare

(CB900F2a - F2c-E,ED F,G,U)

Scheinwerfer

(CB900F2a - F2c-E,ED,F,G,U)

Faro delantero

(CB900F2a - F2c-E,ED,F,G,U)

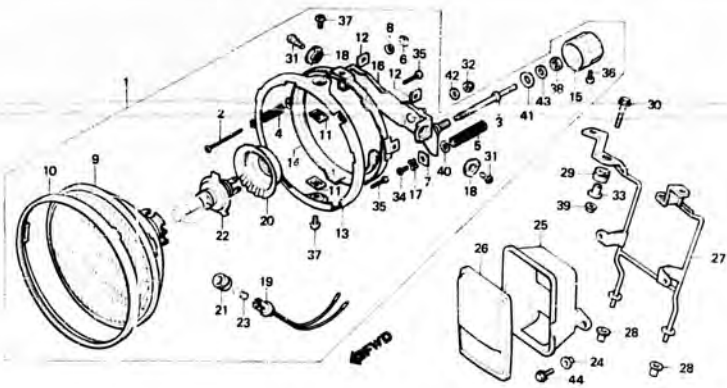

5439-574

Wartungspunkt	AP	Ref. Nr.	Teile-Nr.	Beschreibung	Menge			Serien-Nr.	Gebiets-Code
					Fz	Fa	Fc F2c		
		37	93500-05008-0H	KEGELKOPFSCHRAUBE, 5X8	2	2		E,ED,F,G,U	
		38	94002-12080-US	MUTTER, HEX., 12MM	1	1		E,ED,F,G,U	
		39	94050-06000	FLANSCHENMUTTER, 6MM	2	2		E,ED,F,G,U	
		4J	94101-06800	GLATTE SCHEIBE, 6MM	1	1		E,ED,F,G,U	
		41	94101-12800	GLATTE SCHEIBE, 12MM	1	1		E,ED,F,G,U	
		42	04103-06700	GLATTE SCHEIBE, 6MM	1	1		E,ED,F,G,U	
		43	94111-12800	FEDERRING, 12MM	1	1		E,ED,F,G,U	
		44	95700-06012-00	FLANSCHENSCHRAUBE, 6X12	2	2		F,ED,F,G,U	

G 13

F-1-3

Headlight
(CB900F2B • F2c-DK,DM,SA)

Phare
(CB900F2B • F2c-DK,DM,SA)

Scheinwerfer
(CB900F2B • F2c-DK,DM,SA)

Faro delantero
(CB900F2B • F2c-DK,DM,SA)

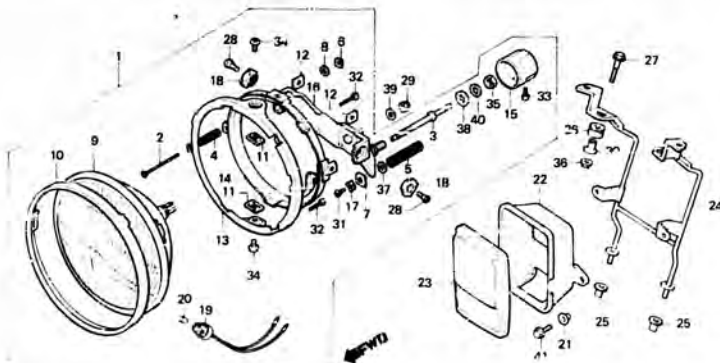

Wartungspunkt	AP	Ref. Nr.	Teile-Nr.	Beschreibung	Menge					Serien-Nr.	Gebiets-Code
					Fz	Ca	Fz	Fz	Fz		
SCHEINWERFER KOMPL.	0.2	1	33100-438-951	SCHEINWERFER KOMPL.	1	1					DK,DM,SA
SCHEINWERFEREINHEIT	0.3	2	33103-346-670	EINSTELLSCHRAUBE, STRAHL	1	1					DK,DM,SA
EINSCHL. DAZUGENDERIGER TEIL		3	33103-438-841	EINSTELLSCHRAUBE, STRAHL	1	1					DK,DM,SA
HALTER, KOPPLER	0.4	4	33107-300-003	EINSTELLFEDER, SCHEINWERFER-	1	1					DK,DM,SA
BEFESTIGUNGSRING B				STRAHL							
BUEGEL, SCHEINWERFER	0.5	5	33107-438-841	EINSTELLFEDER, SCHEINWERFER-	1	1					DK,DM,SA
FESTSTELLSTUETZE, MESSER				STRAHL							
		6	33117-001-023	EINSTELLMUTTER, SCHEINWERFER-	1	1					DK,DM,SA
		7	33117-438-841	EINSTELLMUTTER, STRAHL	1	1					DK,DM,SA
		8	33119-371-003	EINSTELLSCHRAUBE, STRAHL	1	1					DK,DM,SA
		9	33120-415-003	SCHEINWERFEREINHEIT (STANLEY)	1	1					DK,DM,SA
		10	33121-463-771	HALTERING	1	1					DK,DM,SA
		11	33128-292-670	MUTTER, EINHEITHALTER	2	2					DK,DM,SA
		12	33128-438-841	MUTTER, EINHEITHALTER	2	2					DK,DM,SA

G 14

F-1-3

Headlight

(CB900F2B • F2c-DK,DM,SA)

Phase

(CB900F2B • F2c-DK,DM,SA)

Scheinwerfer

(CB900F2B • F2c-DK,DM,SA)

Faro delantero

(CB900F2B • F2c-DK,DM,SA)

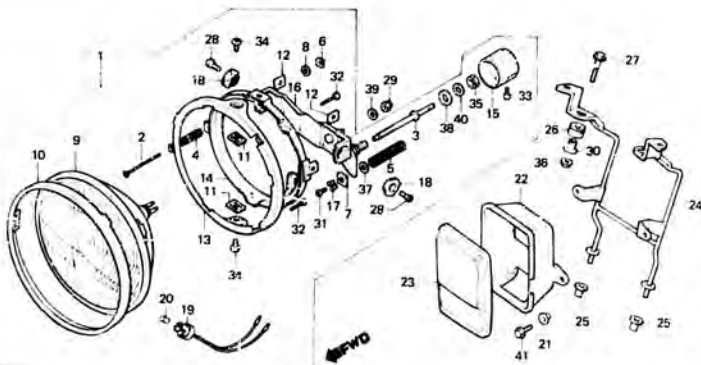

4410-10

Wartungspunkt	AP	Ref. Nr.	Teile-Nr.	Beschreibung	Menge				Serien-Nr.	Gebiets-Code
					Fz	Fa	Fz Fa	Fc F2c		
		13	33153-463-771	BEFESTIGUNGSRING A			1	1		DK,DM,SA
		14	33154-438-841	BEFESTIGUNGSRING B			1	1		DK,DM,SA
		15	33155-463-771	EINSTELKNOPF, STRAHL			1	1		DK,DM,SA
		16	33156-438-841	BUEGEL, SCHEINWERFER			1	1		DK,DM,SA
		17	33157-463-771	FEDERRING			1	1		DK,DM,SA
		18	33165-463-771	SCHLEIBE, SCHEINWERFER			1	1		DK,DM,SA
		19	33170-323-003	SOCKEL KOMPL., ABSTANDSLICHT			1	1		DK,DM,SA
		20	4903-071-003	DIRNE, ABSTANDSLICHT (12V 3,4W) (STANLEY)			1	1		DK,DM,SA
		21	61101-441-000	FESTSTELLHUELSE, V. FENDER			2	2		DK,DM,SA
		22	61305-438-850	HALTER, SIGPLER			1	1		DK,DM,SA
		23	61306-438-850	DECKEL, HALTER			1	1		DK,DM,SA
		24	61311-438-850	FESTSTELLSTUETZE, MESSER			1			DK,DM,SA
			61311-MB7-710	FESTSTELLSTUETZE, MESSER				1		DK,DM,SA
		25	61313-422-000	GUMMITUELLE B, SCHEINWERFER			2	2		DK,DM,SA

G 15

F-1-3

Headlight
(CB900F2B • F2c-DK,DM,SA)

Phare
(CB900F2B • F2c-DX,DM,SA)

Scheinwerfer
(CB900F2B • F2c-DK,DM,SA)

Faro delantero
(CB900F2B • F2c-DK,DM,SA)

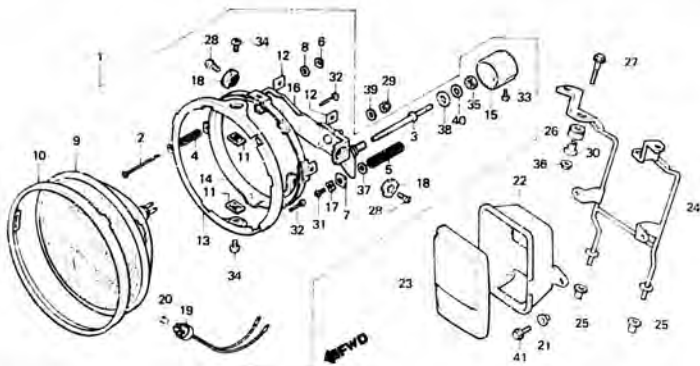

0496

Wartungspunkt	AP	Ref. Nr.	Teile-Nr.	Beschreibung	Menge			Serien-Nr.	Gebiets-Code
					Fz	Fa	Fc		
		26	61316-438-000	BEFESTIGUNGSGUMMI, SCHEINWERFERFESTSTUEZE			2		DK,DM,SA
		27	90002-438-000	FLANSCHENSCHRAUBE, 6X38			2	2	DK,DM,SA
		28	90150-463-771	KEGELKOPFSCHRAUBE, 5X10			2	2	DK,DM,SA
		29	90301-693-000	MUTTER, DEFFNERSTUEZE, 6MM			1	1	DK,DM,SA
		30	90501-438-000	MUELSE, 6X14,3			2	2	DK,DM,SA
		31	93500-03008-0H	KEGELKOPFSCHRAUBE, 3X6			1	1	DK,DM,SA
		32	93500-03012-1A	KEGELKOPFSCHRAUBE, 3X12			2	2	DK,DM,SA
		33	93500-03014-0G	KEGELKOPFSCHRAUBE, 3X14			1	1	DK,DM,SA
		34	93500-05008-0H	KEGELKOPFSCHRAUBE, 5X8			2	2	DK,DM,SA
		35	94002-12080-05	MUTTER, HEX., 12MM			1	1	DK,DM,SA
		36	94050-06000	FLANSCHENMUTTER, 6MM			2	2	DK,DM,SA
		37	94101-06800	GLATTE SCHEIBE, 6MM			1	1	DK,DM,SA
		38	94101-12800	GLATTE SCHEIBE, 12MM			1	1	DK,DM,SA
		39	94103-06700	GLATTE SCHEIBE, 6MM			1	1	DK,DM,SA
		40	94111-12800	FEDERRING, 12MM			1	1	DK,DM,SA
		41	95700-06012-00	FLANSCHENSCHRAUBE, 6X12			2		DK,DM,SA

G 16

F-2

Meter

Compteurs

Messer

Medidor

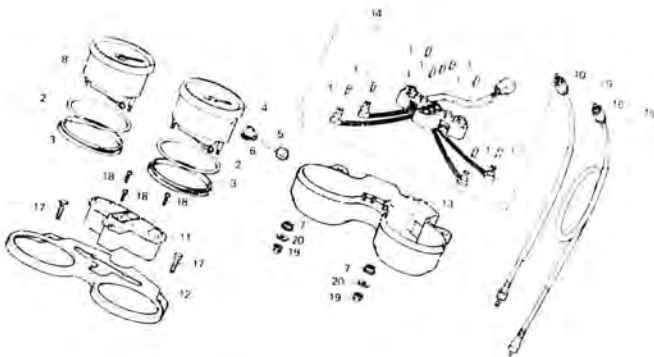

4438-12

Wartungspunkt	AP	Ref. Nr.	Teile-Nr.	Beschreibung	Menue C8900				Serien-Nr.	Gebiets-Code
					Ez	Fa	Fv	Fz		
BIRNE DIE GLEICHE ARBEITSZEIT- PAUSCHALE, AUCH WENN NUR EIN ODER ALLE TEILE GEWARTET WIRD KABEL KOMPL., DREHZAHLMESSE KONTROLLKASTEN KOMPL. KABEL KOMPL., GESCHWINDIGKEITSMESSE GESCHWINDIGKEITSMESSE KOMPL. FESTSTELLPLATTE, MESSER KONTROLLSCHNUR KOMPL. DREHZAHLMESSE ¹⁰ KOMPL. DECKEL, MESSER UNTEN	0,1	1	34902-259-000	BIRNE (12V3,4V)	9	9	9	9	DK, ED, F, G, SA, U	
		2	37114-422-008	MESSERPING	2	2	2	2		
		3	37115-422-008	POLSTER, MESSER	2	2	2	2		
		4	37200-422-111	GESCHWINDIGKEITSMESSE KOMPL. (KPH)	1	1				
			37200-422-612	GESCHWINDIGKEITSMESSE KOMPL. (KPH)		1	1	1	DK, ED, F, G, SA, U	
			37200-422-671	GESCHWINDIGKEITSMESSE KOMPL. (KPH)	1	1			DM, E	
	0,4		37200-422-672	GESCHWINDIGKEITSMESSE KOMPL. (KPH)		1	1	1	DM, E	
	0,3	5	37220-422-008	KNOPF, TAGESKILDMETERZAEHLER	1	1	1	1		
	0,2	4	37221-438-008	GUMMITUELLE, TAGESKILDMETER- ZAEHLERKNOPF	1	1	1	1		
		7	37244-422-000	HALTEGUMMI, MESSER	4	4	4	4		
		8	37250-422-008	DREHZAHLMESSE KOMPL.	1	1	1	1		
			37250-422-601	DREHZAHLMESSE KOMPL.	1	1	1	1	DT, DM, U	
			37250-422-741	DREHZAHLMESSE KOMPL.	1	1	1	1	E, ED, F, G	
		9	37267-438-000	KABEL KOMPL., DREHZAHLMESSE	1	1	1		SA	

H 1

F-2

Meter

Compteurs

Messer

Medidor

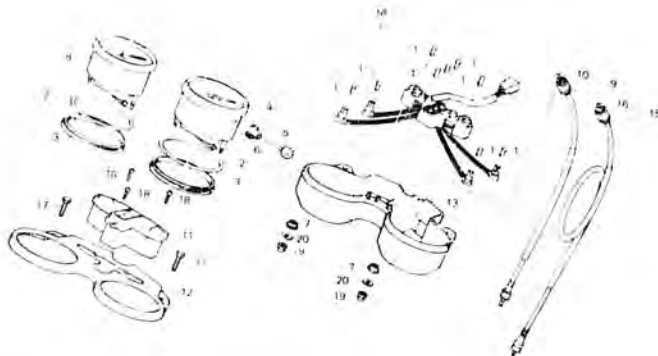

8133 10

Wartungspunkt	AF	Ref. Nr.	Teile-Nr.	Beschreibung	Menge				Serien-Nr	Gebiets-Code
					57	Fa	12a	F. 12c		
		37260-MB7-610		KABEL KOMPL., DREHZÄHLMESSER					1	1
		37261-438-000		KABEL, DREHZÄHLMESSER INNEN	1	1	1	1	1	1
		11 37600-438-708		KONTROLLKASTEN KOMPL.	1	1	1	1	1	1
		12 37610-438-008		FESTSTELLPLATTE, MESSER	1	1	1	1	1	1
		13 37617-438-008		DECKEL, MESSER UNTEN	1	1	1	1	1	1
		14 37619-438-008		KONTROLLSCHNUR KOMPL.	1	1	1	1	1	1
		15 44830-356-010		KABEL KOMPL., GESCHWINDIGKEITSMESSER	1	1	1	1		
		44830-MB7-610		KABEL KOMPL., GESCHWINDIGKEITSMESSER					1	1
		16 44831-356-000		KABEL, GESCHWINDIGKEITSMESSER INNEN	1	1	1	1		
		44831-415-610		KABEL, GESCHWINDIGKEITSMESSER INNEN					1	1
		18 90107-438-000		FESTSTELLSCHRAUBE, MESSER	2	2	2	2	2	2
		19 90500-03008-06		KEGELKOPFSCHRAUBE, 3x8	3	3	3	3	3	3
		20 94021-05071-05		MUTMUTTER, 5MM	4	4	4	4	4	4
		21 94107-05700		GLATTE SCHEIBE, 5MM	4	4	4	4	4	4

1961.11.10

E

H1

H 2

F-2-1

Voltmeter - Clock
(CB900F2b - F2c)

Voltmetre - Montre
(CB900F2b - F2c)

Voltmeter - Quarzuhr
(CB900F2b - F2c)

Voltmetro - Relot
(CB900F2b - F2c)

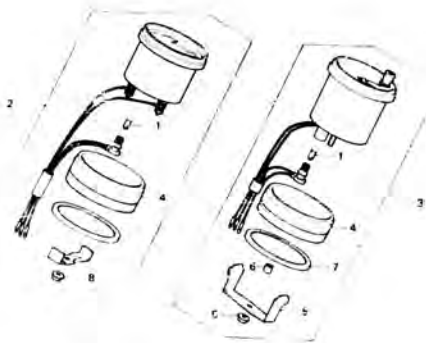

B438-57

Wartungspunkt	AP	Ref. Nr.	Teile-Nr.	Beschreibung	Menge				Serien-Nr.	Gebiets-Code
					F2	Fa	F2a	F2c		
BIRNE	0,1	1	34902-463-711	BIRNE (12V 1,7W STANLEY)			2	2		
VOLTMETER KOMPL.	0,3	2	37520-438-840	VOLTMETER KOMPL.			1	1		
QUARZUHR KOMPL.		3	37460-438-841	QUARZUHR KOMPL.			1	1		
		4	37462-438-840	BEFESTIGUNGSGUMMI			2	2		
		5	37464-438-840	BUEGEL, H.			1	1		
		6	37464-463-710	HUELSE			1	1		
		7	37466-463-710	PLATTE, RING			1	1		
		8	94050-04000	FLANSCHMUTTER, 4MM			1	1		
		9	94050-03000	FLANSCHMUTTER, 3MM			1	1		

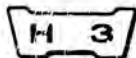

F-3

Handle lever - Switch - Cable

Lavier de poignée - Interrupteur - Câble

Lenkstangenhebel - Schalter - Kabel

Palanca de manubrio - Interruptor - Cable

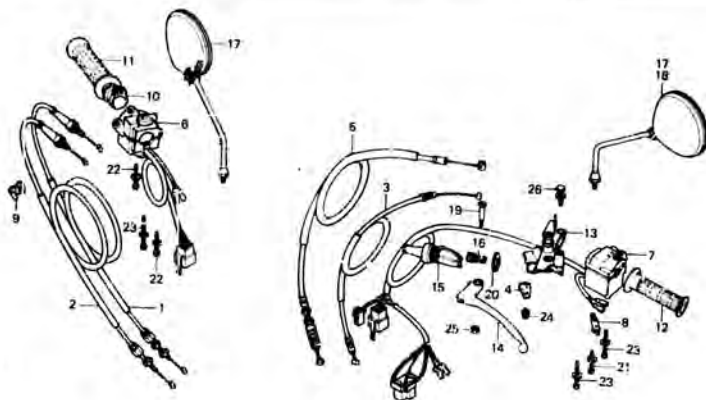

6435-14

Wartungspunkt	AP	Ref. Nr.	Teile-Nr.	Beschreibung	Menge				Serien-Nr.	Gebiets-Code
					Fz	Fa	Fz F2a	Fc F2c		
KABEL KOMPL. DROSSEL (DIE GLEICHE ARBEITSZEIT-PAUSCHALE, AUCH WENN NUR EIN ODER ALLE TEILE GEWARTET WIRD)	0.6	1	17910-425-611	KABEL KOMPL., A, DROSSEL	1	1	1	1		
			17910-425-612	KABEL KOMPL., A, DROSSEL						
			17910-438-850	KABEL KOMPL., A, DROSSEL			1			
ABSCHALTER KOMPL., ANLASSER	0.3	2	17920-425-610	KABEL KOMPL., B, DROSSEL	1	1	1	1		
			17920-425-611	KABEL KOMPL., B, DROSSEL						
			17920-438-850	KABEL KOMPL., B, DROSSEL			1	1	1	1
STARTERKLAPPENKABEL KOMPL., KABEL KOMPL., KUPPLUNG	0.3	3	17950-438-000	STARTERKLAPPENKABEL KOMPL.	1	1	1	1	1	1
			17950-438-850	STARTERKLAPPENKABEL KOMPL.					1	1
ROHR, DROSSELGRIFF										
BUEGEL KOMPL., LENKERHEBEL										
SCHALTER KOMPL., BLINKER	0.5	4	17960-425-000	HALTER, STARTERKLAPPENKABEL	1	1	1	1	1	1
SCHALTER KOMPL., V. HEBEL	0.1	5	22870-438-610	KABEL KOMPL., KUPPLUNG	1	1	1	1	1	1
GRIFF, LENKERHEBEL, LENKER L.			22870-435-750	KABEL KOMPL., KUPPLUNG					1	1
		6	35150-425-602	ABSCHALTER KOMPL., ANLASSER	1	1	1	1	1	1
		7	35200-438-601	SCHALTER KOMPL., BLINKER	1	1	1	1	1	1
		8	35330-413-003	SCHALTER KOMPL., V. HEBEL	1	1	1	1	1	1
		9	46465-422-000	KABELKLEMME	1	1	1	1	1	1
		10	53141-422-000	ROHR, DROSSELGRIFF	1	1	1	1	1	1

H 4

F-3

Handle lever • Switch • Cable

Lavier de poignée • Interrupteur • Câble

Lenkstangenhebel • Schalter • Kabel

Palanca de manubrio • Interruptor • Cable

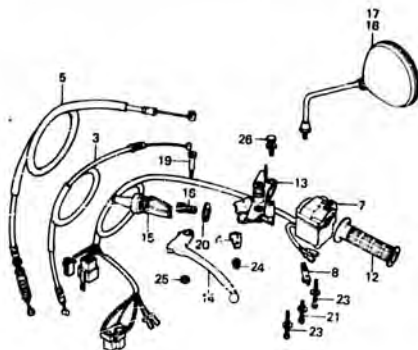
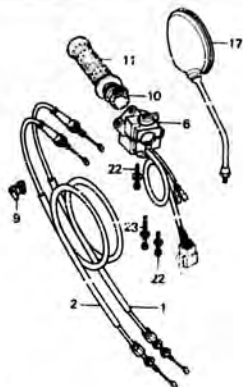

B438-13

Wartungspunkt	AP	Ref. Nr.	Teil-Nr.	Beschreibung	Menge				Serien-Nr	Gebiets-Code
					Fa	Fa	Fc	F2c		
		11	53165-422-000	GRIF, R., LENKER	1	1	1	1		
		12	53166-422-000	GRIF, L., LENKER	1	1	1	1		
		13	53170-422-010	BUEGEL KOMPL., LENKERHEBEL	1					
			53170-422-020	BUEGEL KOMPL., LENKERHEBEL	1				2013306	2013305
						1	1	1		
	1 ^a	53178-422-010	53178-422-010	BUEGEL KOMPL., LENKERHEBEL HEBEL, LENKER L.	1			1		2013305
			53178-422-020	HEBEL, LENKER L.	1				2013306	
	15	53180-422-010	53180-422-020	HANSCHETTE, LENKSTANGENHEBEL NSCHETTE, LENKSTANGENHEBEL	1	1	1	1	1	
						1	1	1	1	
	16	53192-422-000		EINSTELLSCHRAUBE, KARTEL	1	1	1	1	1	
	17	88110-425-013		RUECKSPIEGEL	1					2013549 DK, DM, ED, G, SA
		88110-425-623		RUECKSPIEGEL, R.	1					2011281 F
		88110-425-624		RUECKSPIEGEL	1					2013576 U

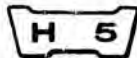

F-3

Handle lever - Switch - Cable

Levier de poignée - Interrupteur - Câble

Lenkstangenhebel - Schalter - Kabel

Palanca de manubrio - Interruptor - Cable

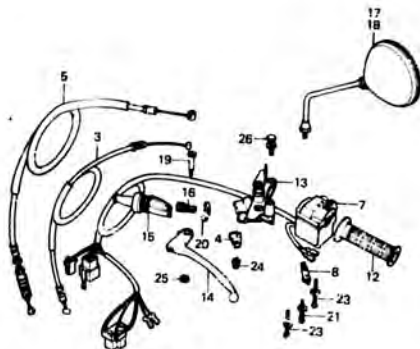
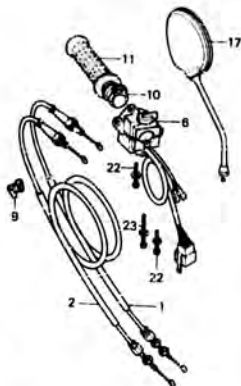

W43B-13

Wartungspunkt	AP	Ref. Nr.	Teile-Nr.	Beschreibung	Menge				Serien-Nr.	Gabiets-Code
					Fz	Fa	Fa F2m	Fc FZc		
			88110-438-003	RUECKSPIEGEL	1				2013950	DK,DM,ED,G,SA
			88110-438-651	RUECKSPIEGEL	1	1	1	1	2013377	DK,DM,ED,G,SA U
			88110-425-624	RUECKSPIEGEL, R.	1				2013196	E
			88110-425-625	RUECKSPIEGEL, R.	1				2011262	2013196
			88110-425-625	RUECKSPIEGEL, R.	1				2013197	U E,F
	18		88110-425-013	RUECKSPIEGEL	1			1	2013549	DK,DM,ED,G,SA
			88110-425-652	RUECKSPIEGEL	1				2013376	U
			88120-425-623	RUECKSPIEGEL, L.	1				2011261	F
			88110-438-003	RUECKSPIEGEL	1				2013550	DK,DM,ED,G,SA
			88110-438-651	RUECKSPIEGEL	1	1	1	1	2013377	DK,DM,ED,G,SA U
			88120-425-624	RUECKSPIEGEL, L.	1			1	2013196	E
			88120-425-625	RUECKSPIEGEL, L.	1				2011262	F
			88120-425-625	RUECKSPIEGEL, L.	1				2013197	E,F E,F
						1	1	1		

H 6

F-3

Handle lever • Switch • Cable

Levier de poignée • Interrupteur • Câble

Lenkstangenhebel • Schalter • Kabel

Palanca de manubrio • Interruptor • Cable

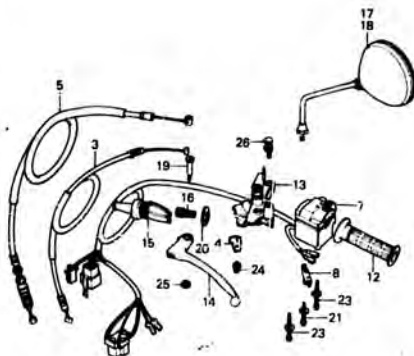
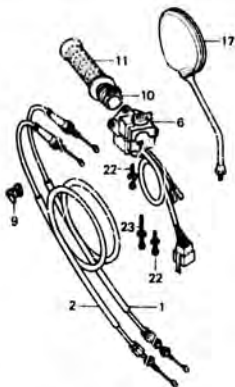

B13R-13

Wartungspunkt	AP	Ref. Nr.	Teile-Nr.	Beschreibung	Menge				Serien-Nr.	Gebiets-Code
					Fz	FA	Fa	F2c		
		19	90113-422-000	ZAPFENBOLZEN, L. LENKSTANGEN-HEBEL	1					2013305
			90113-438-000	ZAPFENBOLZEN, L. LENKSTANGEN-HEBEL	1					
		20	90321-422-000	FIXIERMUTTER	1	1	1	1	1	2013306
					1	1	1	1	1	
		21	93891-05028-07	SCHRAUBE MIT SCHEIBE, 5X28	1	1	1	1	1	
		22	93891-05032-07	SCHRAUBE MIT SCHEIBE, 5X32	2	2	2	2	2	
		23	93891-05043-07	SCHRAUBE MIT SCHEIBE, 3X45	3	3	3	3	3	
		24	93892-05010-07	SCHRAUBE MIT SCHEIBE, 3X10	1	1	1	1	1	
		26	94002-06000	MUTTER, HEX., 6MM	1	1	1	1	1	
		26	95700-08025-07	FLANSCHSCHRAUBE, 6X25	1	1	1	1	1	

H 7

F-4

**Front brake master cylinder
(CB900Fz · FA · Fb · F2a)**

**Maître cylindre de frein avant
(CB900Fz · FA · Fb · F2a)**

**Vorderradbremse-Hauptzylinder
(CB900Fz · FA · Fb · F2a)**

**Cilindro maestro de freno delantero
(CB900Fz · FA · Fb · F2a)**

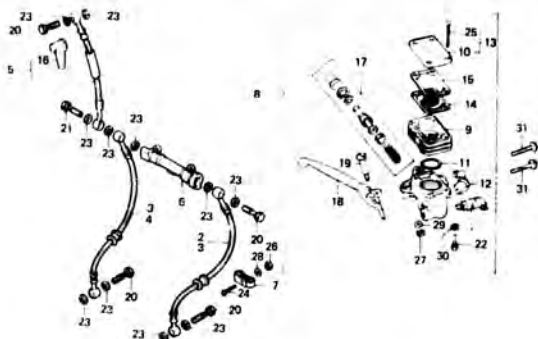

B438 - 05

Wartungspunkt	AP	Ref. Nr.	Teile-Nr.	Beschreibung	Menge				Serien-Nr.	Gebiets-Code
					Fz	FA	Fb	F2a Fc F2c		
BREMSSCHALTER KOMPL., V. MEMBRANE	0.1	1	35340-422-003	BREMSSCHALTER KOMPL., V.	1				2015668	DK,DM,SA,U
HEBEL, LENKER R.					1				2015306	E,ED,F,G
SCHLAUCH V. BREMSE			35340-422-013	BREMSSCHALTER KOMPL., V.	1				2015669	E,ED,F,G
(WENN DIE KOMP. EINHEIT GEWARTET WIRD, BETRAEGT DIE ARBEITSZEIT-PAUSCHALE 0,4.)	0.3				1				2015307	DK,DM,SA,U E,ED,F,G
VERBINDUNG			2 45124-438-731	BREMSSCHLAUCH, L. V.	1	1	1			2203276
HAUPTZYLINDER KOMPL., V. DELBECHER	0.2		45124-438-671	BREMSSCHLAUCH, L. V.			1	1	2203277	4000011
HAUPTZYLINDER KOMPL., V. DELBECHER	0.2	3	45125-438-003	SCHLAUCH A, V. BREMSE	2			1	4000012	
HAUPTZYLINDER KOMPL., V. DELBECHER	0.4		45125-438-013	SCHLAUCH A, V. BREMSE (NICHIRIN)	2					
		4	45125-438-731	BREMSSCHLAUCH, R. V.			1	1	2203276	4000011
			45125-438-671	BREMSSCHLAUCH, R. V.			1	1	2203277	4000012
		5	45126-438-013	SCHLAUCH G, V. BREMSE	1			1		
			45126-438-023	SCHLAUCH B, V. BREMSE (NICHIRIN)			1			
			45126-438-731	SCHLAUCH B, V. BREMSE			1	1		

H 8

F-4

From orake master cylinder
(CB900Fz • FA • Fb • F2b)

Maitre cylindre de frein avant
(CB900Fz • FA • Fb • F2b)

Vorderradbremse-Hauptzylinder
(CB900Fz • FA • Fb • F2b)

Cilindro maestro de freno delantero
(CB900Fz • FA • Fb • F2b)

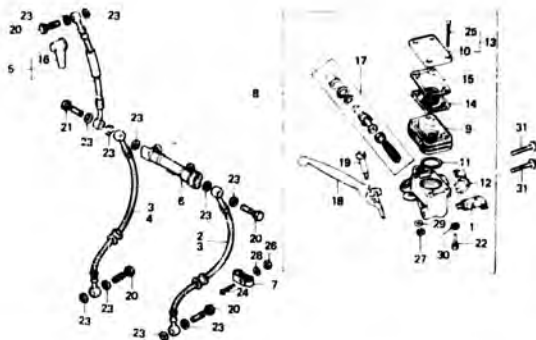

B438-55

Wa: tungspunkt	AP	Ref. Nr.	Teile-Nr.	Beschreibung	Menge				Serien-Nr.	Gebiets-Code
					Fz	FA	Fb F2b	Fc F2c		
		6	45127-422-003	VERBINDUNG	1	1	1			
		7	45128-463-000	KLAMMER, BREMSCHLAUCH	1	1	1			
		8	45500-438-611	HAUPTZYLINDER KOMPL., V.	1	1	1		2010261 E,ED,F,G	
			45500-438-612	HAUPTZYLINDER KOMPL., V.						
			45500-438-651	HAUPTZYLINDER KOMPL., V.	1				2010231 DK,DM,SA,U	
			45500-438-612	HAUPTZYLINDER KOMPL., V.	1			2010262	2013096 E,ED,F,G	
			45500-438-652	HAUPTZYLINDER KOMPL., V.	1			2010232	2013096 DK,DM,SA,U	
			45500-438-613	HAUPTZYLINDER KOMPL., V.	1			2013097	2015306 E,ED,F,G	
			45500-438-653	HAUPTZYLINDER KOMPL., V.	1			2013097	2015668 DK,DM,SA,U	
			45500-438-613	HAUPTZYLINDER KOMPL., V.	1			2015307	E,ED,F,G	
			45500-438-655	HAUPTZYLINDER KOMPL., V. BREMSE	1	1			E,ED,F,G	
			45500-438-651	HAUPTZYLINDER KOMPL., V. BREMSE	1			2015669	E,ED,F,G	
			45500-463-601	HAUPTZYLINDER KOMPL., V. BREMSE	1	1			DK,DM,SA,U	
			45500-415-762	HAUPTZYLINDER KOMPL., V. BREMSE	1	1			E,ED,F,G	
		9	45111-438-006	DELBECHER	1	1				
			45111-463-006	DELBECHER	1	1	1			
		10	45113-427-651	KAPPE, DELBECHER	1				2010231 DK,DM,SA,U	

H 9

F-4

Front brake master cylinder
(CB900Fz · FA · Fb · F2a)

Maitre cylindre de frein avant
(CB900Fz · FA · Fb · F2a)

Vorderradbremse-Hauptzylinder
(CB900Fz · FA · Fb · F2a)

Cilindro maestro de freno delantero
(CB900Fz · FA · Fb · F2a)

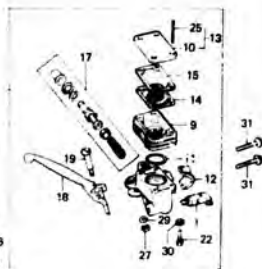
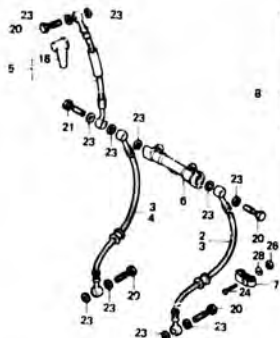

B438-55

Wartungspunkt	AP	Ref. Nr.	Teile-Nr.	Beschreibung	Menge				Serien-Nr.	Gebiets-Code
					Fz	Fa	Fb	Fc F2c		
		45513-443-611	KAPPE, DELBECHER	1					2010261	E,ED,F,G
		45519-443-611	KAPPE, DELBECHER	1					2010232	DK,DM,SA,U
		45513-422-652	KAPPE, DELBECHER	1	1	1	1		2010262	DK,DM,SA,U
		45513-443-612	KAPPE, DELBECHER	1	1	1	1		2010262	E,ED,F,G
		45513-443-612	KAPPE, DELBECHER	1	1	1	1		2010262	E,ED,F,G
		11 45516-422-006	O-RING, 39.7X3.5	1	1	1	1			
		12 45517-422-006	HALTER, HAUPTZYLINDER	1	1	1	1			
		13 45519-422-651	KAPPE SATZ, DELBECHER	1					2010231	DK,DM,SA,U
		14 45519-443-611	KAPPE SATZ, DELBECHER	1					2010261	E,ED,F,G
		14 45520-422-006	MEMBRANE	1					2010261	E,ED,F,G
		45520-422-016	MEMBRANE	1					2010232	DK,DM,SA,U
		45520-422-016	MEMBRANE	1					2010262	E,ED,F,G
		15 45521-422-006	PLATTE, MEMBRANE	1	1	1	1			
		15 45521-422-006	PLATTE, MEMBRANE	1	1	1	1			
		16 45522-422-000	MANSCHETTE, HAUPTZYLINDER	1	1	1	1			

H 10

F-4

Front brake master cylinder
(CB900Fz • FA • Fz • F2B)

Maitre cylindre de frein avant
(CB900Fz • FA • Fz • F2B)

Vorderradbremse-Hauptzylinder
(CB900Fz • FA • Fz • F2B)

Cilindro maestro de freno delantero
(CB900Fz • FA • Fz • F2B)

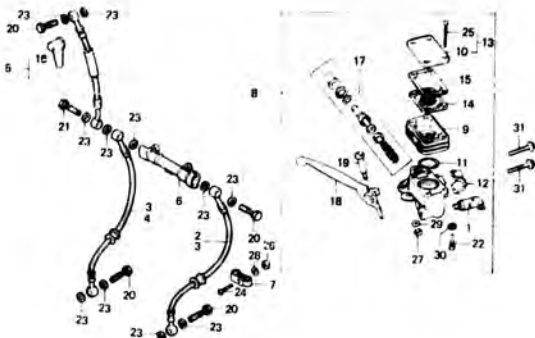

B4.18 - 55

Wartungspunkt	AP	Ref. Nr.	Teile-Nr.	Beschreibung	Menge			Serien-Nr.	Gebiets-Code
					Fz	FA	CB900 Fz, F2a, Fz, F2c		
		17	45530-422-305	HAUPTZYLINDER SATZ, V.	1	1			
			45530-422-315	HAUPTZYLINDER SATZ, V.			1	1	
		18	53175-438-000	HEBEL, LENKER R.	1				2013096
			53175-438-010	HEBEL, LENKER R.	1				2013097
			53175-422-000	HEBEL, LENKER R.			1	1	
		19	90114-422-000	ZAPFENBOLZEN, R. LENKSTANGEN-HEBEL	1	1	1	1	
		20	90145-300-000	SCHRAUBE, OEL	4	4	4	4	
		21	90145-422-010	SCHRAUBE, OEL	1	1	1	1	
		22	90183-422-000	KEGELKOPFSCHRAUBE, 4x13,5	1	1	1	1	
		23	90545-300-000	SCHLEIFE, OELSCHRAUBE	11	11	11	11	
		24	93500-04020-0A	KEGELKOPFSCHRAUBE, 4x20			1	1	
		25	93600-04037-1G	FLACHKOPFSCHRAUBE, 4x37	4				2010231 DK, DM, SA, U
			90137-422-006	KOPFSCHRAUBE, 4x35	4				2010261 E, ED, F, G
					4				2010232 DK, DM, SA, U
					4	4	4		2010262 E, ED, F, G

H 11

F-4

Front brake master cylinder
(CB900Fz • FA • F8 • F2s)

Maître cylindre de frein avant
(CB900Fz • FA • F8 • F2s)

Vorderradbremse-Hauptzylinder
(CB900Fz • FA • F8 • F2s)

Cilindro maestro de freno delantero
(CB900Fz • FA • F8 • F2s)

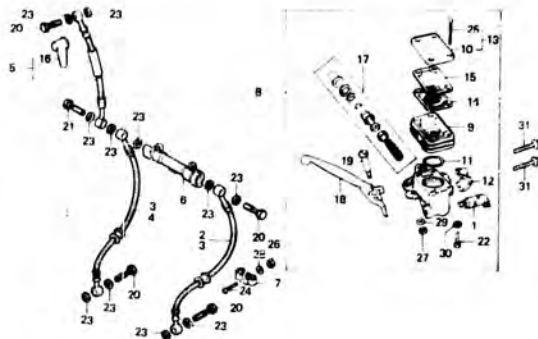

B438-55

Wartungspunkt	AP	Ref. Nr.	Teile-Nr.	Beschreibung	Menge				Serien-Nr.	Gebiets-Code
					Fz	FA	F8	F2s		
		26	94002-04000-05	MUTTER, HEX., 4MM		1	1	1		
		27	94002-06000-05	MUTTER, HEX., 6MM		1	1	1		
		28	94101-04000	GLATTE SCHEIBE, 4MM			1	1		
		29	94101-06000	GLATTE SCHEIBE, 6MM		1	1	1		
		30	94111-04000	FEDERRING, 4MM		1	1	1		
		31	95700-5025-07	FLANSCHENSCHRAUBE, 6x25	2	2	2	2		

H 12

F-4-1

Front brake master cylinder
(CB900Fc - F2c)

Maitre cylindr de trin avant
(CB900Fc - F2c)

Vorderradbremse-Hauptzylinder
(CB900Fc - F2c)

Cilindro maestro de freno delantero
(CB900Fc - F2c)

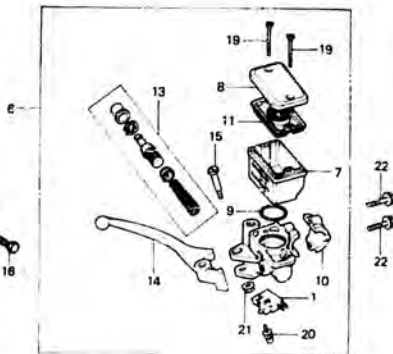
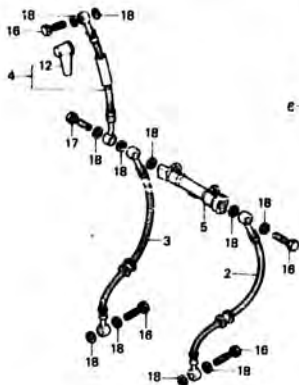

9438-110

Wartungspunkt	AP	Ref. Nr.	Teile-Nr.	Beschreibung	Menge			Serien-Nr.	Gebiets-Code
					Fz	Fa	Fz Fa F2a		
BREMSSCHALTER KOMPL., V.	0,1	1	35340-MA5-671	BREMSSCHALTER KOMPL., V.			1	1	
MEMBRANE		2	45124-MB7-611	BREMSSCHLAUCH, L. V.			1	1	
HEBEL KOMPL., LENKER		3	45125-MB7-611	BREMSSCHLAUCH, R. V.			1	1	
BREMSSCHLAUCH, R. V.	0,3	4	45126-438-731	SCHLAUCH B. V. BREMSE			1	1	
(WENN DIE KOMP. EINHEIT GEWARTET WIRD, BETRAEGT DIE ARBEITSZEIT-PAUSCHALE 0,4.)		5	45127-422-003	VERBINDUNG			1	1	
HAUPTZYLINDER KOMPL., V.	0,2	6	45500-445-651	HAUPTZYLINDER KOMPL., V.			1	1	
DELBECHER		7	45511-MA5-671	DELBECHER			1	1	
HAUPTZYLINDER KOMPL., V.	0,2	8	45513-MA5-571	KAPPE DELBECHER			1	1	
DELBECHER		9	45516-166-006	O-RING			1	1	
EINSCHL. DAZUGEHÖRIGER TEIL	0,4	10	45517-MA5-671	HALTER, HAUPTZYLINDER			1	1	
HAUPTZYLINDER SATZ		11	45520-MA5-671	MEMBRANE			1	1	
		12	45522-422-000	HAUSCHETTE, HAUPTZYLINDER			1	1	
		13	45530-MA5-671	HAUPTZYLINDER SATZ			1	1	
		14	53175-MA5-671	HEBEL KOMPL., R. LENKER			1	1	

H 13

F-4-1

Front brake master cylinder
(CB900Fc - F2c)

Maître cylindre de trin avant
(CB900Fc - F2c)

Vorderradbremse-Hauptzylinder
(CB900Fc - F2c)

Cilindrio maestro de freno delantero
(CB900Fc - F2c)

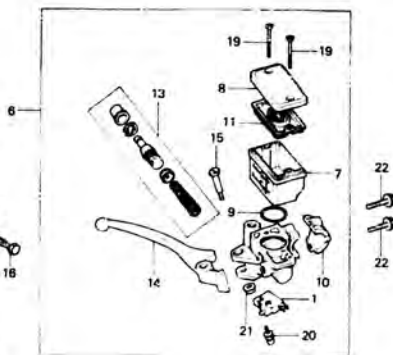
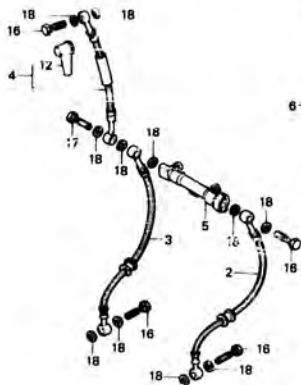

8438-110

Wartungspunkt	AP	Ref. Nr.	Teile-Nr.	Beschreibung	Menge				Serien-Nr.	Gebiets-Code
					F2	Fa	Fc	F2c		
		15	90114-HA3-671	ZAPFENBOLZEN, F. LENKSTANGEN-HEBEL			2	2		
		16	90145-300-000	SCHRAUBE, DEL			4	4		
		17	90145-422-010	SCHRAUBE, DEL			1	1		
		18	90545-300-000	SCHIBE, DELSCHRAUBE			11	11		
		19	93600-04045-16	FLACHKOPFSCHRAUBE, 4x45			2	2		
		20	93893-04012-18	SCHRAUBE MIT SCHIBE, 4x12			1	1		
		21	9A050-06000	FLANSCHENMUTTER, 6MM			1	1		
		22	93700-06025-07	FLANSCHENSCHRAUBE, 6x25			2	2		

1981.11.10

E

H13

H 14

F-5

Handle pipe - Top bridge

Guidon - Haut de fourche

Lenkrohr - Obere Brücke

Tubo do manubrio - Puente superior

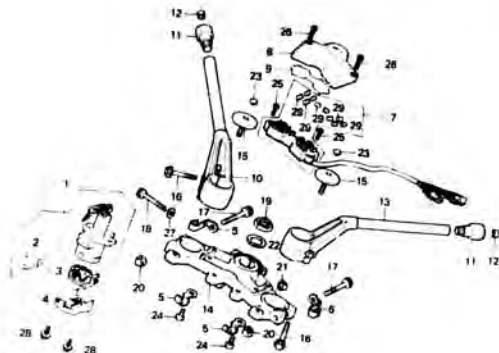

B438-55

Wartungs-inkt	AP	Ref. Nr.	Teile-Nr.	Beschreibung	Menge C8900				Serien-Nr.	Gebiets-Code	
					Fz	Fa	Fz	Fz			
SCHLOSS SATZ	0,4	1	35010-438-610	SCHLOSS SATZ	1	1				E, ED, F, G	
KOMBINATIONSSCHALTER	0,3	1	35010-438-680	SCHLOSS SATZ	1	1				DK, DM, SA, U	
KOMPL.,			35010-443-850	SCHLOSS SATZ			1	1	1	1	DK, DM, E, F, SA, U
KOMBINATIONSSCHALTER KOMPL.,			35010-443-860	SCHLOSS SATZ			1	1	1	1	ED, G
BASIS KOMPL., KONTAKT		2	35100-438-007	KOMBINATIONSSCHALTER KOMPL.,	1	1	1	1	1	1	DK, DM, SA, U
PLATTE KOMPL., SICHERUNG			35100-438-601	KOMBINATIONSSCHALTER KOMPL.,	1	1					E, F
LENKROHR, R.							1	1	1	1	E, ED, F, G
(Fa, Fz, FzC-AUSFUEHRUNG 0,4)							1	1	1	1	ED, G
LENKROHR, L.		3	35101-422-007	BASIS KOMPL., KONTAKT	1	1	1	1	1	1	
(Fa, Fz, FzC-AUSFUEHRUNG 0,4)		4	35102-431-007	DECKEL, SCHALTER	1	1	1	1	1	1	
DECKEL, SICHERUNGSPLATTE	0,1	5	35210-438-000	KLAMMER, SCHALTERSCHNUR	2	2	2	2	2	2	
GEWICHT, LENKER		6	35211-438-000	KLAMMER, SCHALTERSCHNUR	2	2	2	2	2	2	
(DIS GLEICHE ARBEITSZEIT-PAUSCHALE- AUCH WENN NUR EIN ODER ALLE TEILL GEWARTET WIRD)		7	38200-422-005	PLATTE KOMPL., SICHERUNG	1	1	1	1	1	1	
BRUECKE, GABEL OBEN	0,6	8	38210-422-000	DECKEL, SICHERUNGSPLATTE	1	1	1	1	1	1	
(Fa, Fz, FzC-AUSFUEHRUNG 0,7)		9	38213-438-300	ZETTEL, SICHERUNG	1	1	1	1	1	1	
			38215-438-620	ZETTEL, SICHERUNG (FRENCH)	1	1	1	1	1	1	DK, DM, F, ED, G, SA, U
		10	53100-438-620	LENKROHR, R.	1	1					F

H 15

F-5

Handle pipe - Top bridge

Guidon - Haut de fourche

Lenkrohr - Obere Brücke

Tubo do manubrio - Puente superior

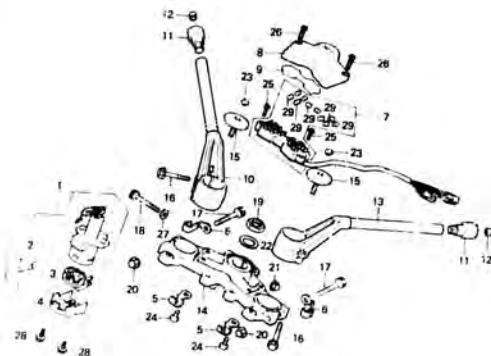

E436-50

Wartungspunkt	AP	Ref. Nr.	Teile-Nr.	Beschreibung	Menge					Serien-Nr.	Gebiets-Code
					Fr	Fa	Fa	F23	Fc		
			53100-438-730	LENKROHR, R.			1				
			53100-438-850	LENKROHR, R.				1			
			53107-MB7-610	LENKROHR, R.					1		
			53100-MB7-710	LENKROHR, R.						1	
	11		53105-438-000	GEWICHT, LENKER	2	2	2	2	2	2	
	12		53110-438-000	STOEPSEL, LENKERGEWICHT	2	2	2	2	2	2	
	13		53150-438-610	LENKROHR, L.	1	1					
			53150-438-730	LENKROHR, L.				1			
			53150-438-850	LENKROHR, L.					1		
			53150-MB7-610	LENKROHR, L.						1	
			53150-MB7-710	LENKROHR, L.							1

H 16

F-5

Handle pipe • Top bridge

Guidon • Haut de fourche

Lenkrohr • Obere Brücke

Tubo do manubrio • Puente superior

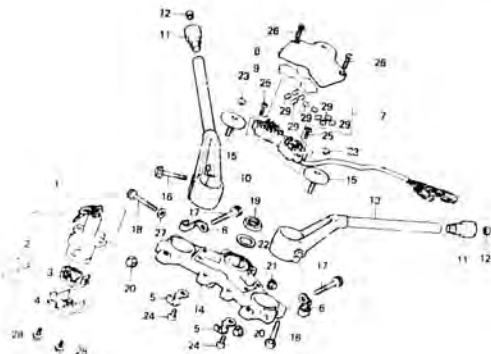

5130-114

Wartungspunkt	AP	Ref. Nr.	Teile-Nr.	Beschreibung	Menge				Serien-Nr.	Gebiets-Code
					F2	Fa	CB90D Fz	Fc 12c		
		14	53230-422-000	BRUECKE, GABEL OBEN	1					
			53230-469-000	BRUECKE, GABEL OBEN		1				
			53230-MA3-000	BRUECKE, GABEL OBEN			1	1		
			53230-HB7-610	BRUECKE, GABEL OBEN					1	1
		15	90107-422-000	FESTSTELLSCHRAUBE, LENKER	2	2				
		16	90153-438-000	FESTSTELLSCHRAUBE, LENKER	2	2	2	2	2	2
		17	90167-422-000	INNENSECHSKANTSCHRAUBE, 7x55	2	2	2	2	2	2
		18	90168-422-000	INNENSECHSKANTSCHRAUBE, 7x75	1	1	1	1	1	1
		19	90304-425-000	MUTTER- STEUERKOPFSCHAFT	1	1	1	1	1	1
		20	90360-422-000	MUTMUTTER, 7MM	2	2	2	2	2	2
		21	90443-379-690	MUTMUTTER, 8MM	1	1	1	1	1	1
		22	90503-425-000	SCHIEBE, STEUERKOPFSCHAFT	1	1	1	1	1	1
		23	91456-371-770	KARPE, INNENSECHSKANTSCHRAUBE	2	2	2	2	2	2
		24	93500-05008-0G	KEGELKOPFSCHRAUBE, 5x8	2	2	2	2	2	2
		25	93500-05016-0A	KEGELKOPFSCHRAUBE, 5x16	2	2	2	2	2	2
		26	93500-05020-0G	KEGELKOPFSCHRAUBE, 5x20	2	2	2	2	2	2
		27	94102-08700	GLATTE SCHEIBE, 8MM	1	1	1	1	1	1

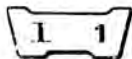

F-5

Handle pipe • Top bridge

Guidon • Haut de fourche

Lenkrohr • Obere Brücke

Tubo de manubrio • Puente superior

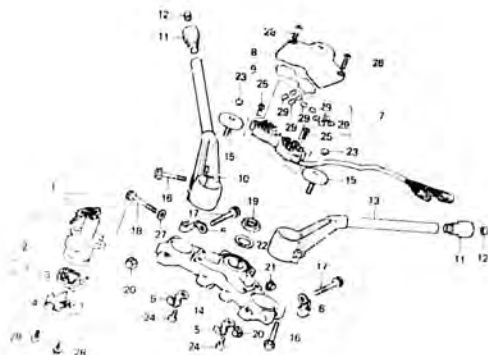

B438-56

Wartungspunkt	AP	Ref. Nr.	Teile-Nr.	Beschreibung	Menge				Serien-Nr.	Gebiets-Code
					F1	Fa	Fv, F2a	Fv, F2c		
		28	95700-79012-00	FLANSCHSCHRAUBE, 6X12	2	2	2	2		
		29	98200-2-20	SICHERUNG B (15A)	5	5	5	5		

1 2

F-6

Steering stem

Tige de direction

Steuerkopfschaft

Varilla de dirección

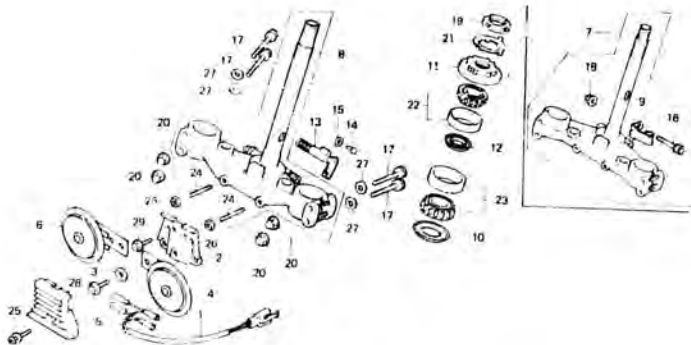

B38-57

Wartungspunkt	AP	Ref. Nr.	Teile-Nr.	Beschreibung	Menge C4900				Serien-Nr.	Gebiets-Code
					Fc	Fa	Fa F2a	Fc F2c		
HILFSKABELBAUM A	0,2	1	32101-438-000	HILFSKABELBAUM A	1	1		1		
HUPE KOMPL.	0,1	2	38102-438-004	SZUETZE, HUPE	1	1		1		
LENKE/SCHLOSS KOMPL.		3	38106-410-004	GLATTE SCHEIBE, 20MM	2					
STEUERKOPFSCHAFT KOMPL.	1,1 (1,4)	4	38110-438-004	HUPE KOMPL. (HIGH)	2	2		2		
LENKER/SCHLOSS KOMPL.	0,5		38110-438-601	HUPE KOMPL. (HIGH)	1	1		1		DK,DM,SA,U
GEWINDKOPF, LENKERKOPF (Fz, F2a, F2c-AUSFUHRUNG 0,6)		5	38111-438-000	EMBLEM, HUPE	1	1		1		E,ED,F,G
LAGER, KOPFRHR OBEN (D1/ GLEICHE ARBEITSGRÖSSE 17-18)	1,0 (1,3)	6	38120-438-004	HUPE KOMPL. (LDW)	1	1		1		DK,DM,SA,U
HAUSCHALE, AUCH WENN NJR EIN ODER ALLE TEILE GEWARTET WIRD			38120-438-601	HUPE KOMPL. (LDW)	1	1		1		E,ED,F,G
		7	53200-438-610	STEUERKOPFSCHAFT KOMPL.	1					E,ED,F,G
			53200-438-611	STEUERKOPFSCHAFT KOMPL.						DK,DM,SA,U
			53200-438-680	STEUERKOPFSCHAFT KOMPL.		1				E,ED,F,G
	1: F2a F2c TYP	8	53200-438-660	STEUERKOPFSCHAFT KOMPL.			1	1		DK,DM,E,F,SA,U
			53200-438-730	STEUERKOPFSCHAFT KOMPL.			1	1		ED,G
			53200-438-610	STEUERKOPFSCHAFT KOMPL.					1	ED,G
			53200-438-670	STEUERKOPFSCHAFT KOMPL.					1	DK,DM,E,F,SA,U

I 3

F-6

Steering stem

Tige de direction

Steuerkopfschaft

Varilla de dirección

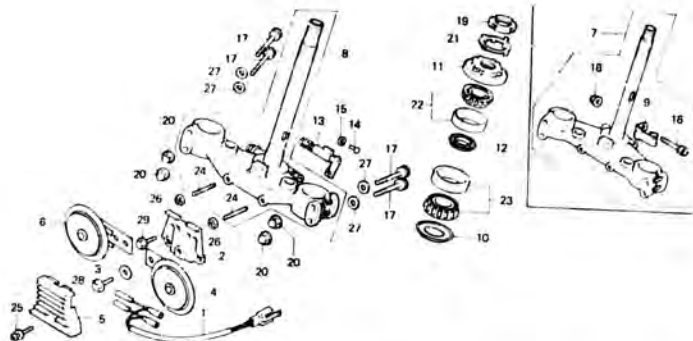

B438-57

Wartungspunkt	AP	Ref. Nr.	Teile-Nr.	Beschreibung	Menge				Serien-Nr.	Gebiets-Code
					Fx	Fa	Fc	F2c		
		9	52003-438-000	FUEHRUNG, GESCHWINDIGKEITS-MESSERKABEL	1	1				
		10	53214-371-010	STAUBDICHTUNG, LENKERKOPF	1	1	1	1	1	
		11	53220-422-000	GEWINDE KOHPL., LENKERKOPF	1	1	1	1	1	
		12	53223-371-010	HALTER, SCHMITZE	1	1	1	1	1	
		13	53600-404-610	LENKERSCHLOSS KOHPL.	1	1				E, ED, F, G
		14	53603-051-000	NIET, 4,1MM	1	1				ED, G
		15	53604-098-940	SCHIEBE, 4,5MM	1	1	1	1	1	E, ED, F, G
					1	1	1	1	1	ED, G
		16	90165-422-000	INNENSECHSKANTSCHRAUBE, 10X65	1	1				
		17	90164-422-000	INNENSECHSKANTSCHRAUBE, 8X55	4	4	4	4	4	
		18	90202-329-000	FLANSCHMUTTER, 12MM	1	1				
		19	90302-425-830	DRUCKGEWINDE B, STEUERKOPF	1	1	1	1	1	

I 4

F-6

Steering stem

Tige de direction

Steuerkopfschaft

Varilla de dirección

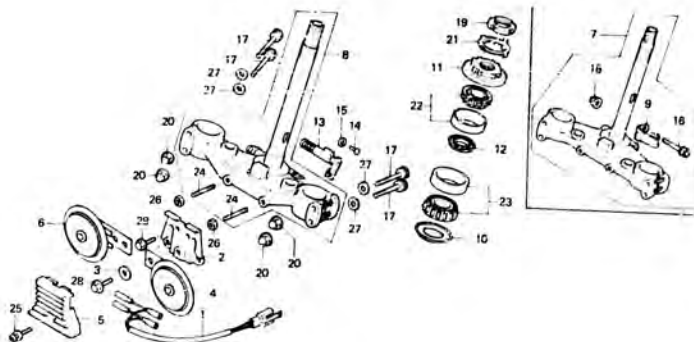

B430-5.1

Wartungspunkt	AP	Ref. Nr.	Teile-Nr.	Beschreibung	Menge				Serien-Nr.	Gebiets-Code
					Fz	FA	Fa	FZc		
		20	90443-107-000	MUTTER, 6MM	4	4	4	4	4	4
		21	90506-425-830	SICHERUNGSSCHEIBE	1	1	1	1	1	1
		22	91013-371-000	LAGER, KOPFRÖHR OBEN (NACHI)	1					
			91013-425-831	LAGER, KOPFRÖHR OBEN (TOYO)	1	1	1	1	1	1
			91013-425-832	LAGER, KOPFRÖHR OBEN (NACHI)	1	1	1	1	1	1
		23	91016-371-000	LAGER, KOPFRÖHR UNTEN	1	1	1	1	1	1
		24	92700-06032-08	STENBOLZEN, 6X32	1	1	2	2	2	2
		25	93891-05020-07	SCHRAUBE MIT SCHEIBE, 5X20	1	1	1	1	1	1
		26	94001-06000-05	MUTTER, HEX., 6MM			2	2	2	2
		27	54132-08000	GLATTE SCHEIBE, 6MM	4	4	4	4	4	4
		28	95700-06012-00	FLANSCHSCHRAUBE, 6X12	2	2	2	2	2	2
		29	95700-06025-00	FLANSCHSCHRAUBE, 6X25	2	2	2	2	2	2

I 5

F-7

Front fender

Garde-boue avant

Vorderer Kotflügel

Parafango delantero

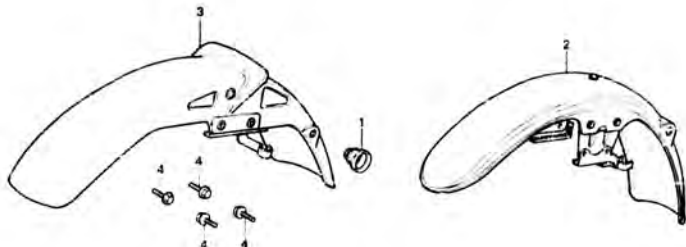

0178-98

Wartungspunkt	AP	Ref. Nr.	Teile-Nr.	Beschreibung	Menge				Serien-Nr.	Gebiets-Code
					F1	Fa	Fb	F2c		
GUMMITUELLE, DRAHT FENDER KOMPL., V.	0-1	1	45451-367-690	GUMMITUELLE, DRAHT	1					
	0-2		45451-471-000	GUMMITUELLE, DRAHT	1	1	1	1	1	
		2	61100-438-000ZA	FENDER KOMPL., V. *NH-10AM-U*	1					2011581
			61100-438-010ZA	FENDER KOMPL., V. *R-33*	1					2011581
			61100-438-000ZB	FENDER KOMPL., V. *PB-107C-U*	1					2011581
			61100-438-010ZB	FENDER KOMPL., V. *NH-10AM-U*	1					2011582
			61100-438-010ZC	FENDER KOMPL., V. *R-33*	1					2011582
			61100-438-010ZD	FENDER KOMPL., V. *NH-1*	1					2011582
			61100-438-020ZA	FENDER KOMPL., V. *NH-10AM-U*	1					E, ED, F, G
			61100-438-020ZC	FENDER KOMPL., V. *PB-107C-U*	1					
			61100-438-020ZD	FENDER KOMPL., V. *NH-1*	1					

I 6

F-7

Front fender

Garde-boue avant

Vorderer Kotflügel

Parafang delantero

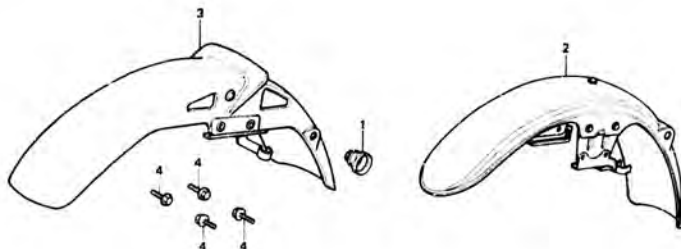

B438-58

Wartungspunkt	AP	Ref. Nr.	Teile-Nr	Beschreibung	Menge					Serien-Nr.	Gebiets-Code	
					Fz	Fa	Fs	Fz	Fc			Fz
		3	61100-438-020ZE	FENDER KOMPL., V. #R-107C-U#						1		
			61100-443-630ZB	FENDER KOMPL., V. #NH-1#						1		
			61100-443-630ZC	FENDER KOMPL., V. #PB-107C-U#						1		
			61100-443-630ZD	FENDER KOMPL., V. #R-107C-U#						1		
			61100-446-830ZE	FENDER KOMPL., V. #R-110#						1		
			61100-449-630ZG	FENDER KOMPL., V. #NH-110H-U#						1	1	
			61100-MB7-610ZA	FENDER KOMPL., V. #NH-121P-A#								1
			61100-MB7-610ZB	FENDER KOMPL., V. #NH-1#								1
			61100-MB7-610ZC	FENDER KOMPL., V. #R-107C-U#								1
			61100-MB7-610ZD	FENDER KOMPL., V. #PB-107C-U#								1
			61100-MB7-610ZE	FENDER KOMPL., V. #R-110#								1

I 7

F-7

Front fender

Garde-boue avant

Vorderer Kotflügel

Parafango delantero

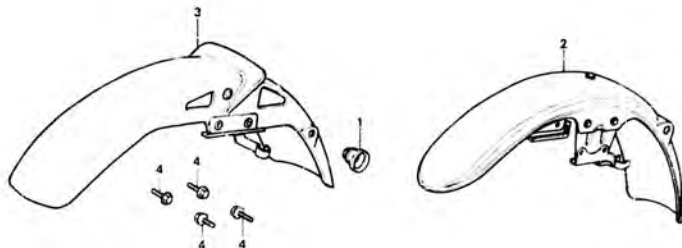

8438 - 58

Wartungspunkt	AP	Ref. Nr.	Teile-Nr.	Beschreibung	Menge					Serien-Nr.	Gebiets-Code	
					Fr	Fa	Fa	F2a	Fc			F2c
				61100-MB7-610ZF FENDER KOMPL., V. *NH-110H-U*						1		
			4	93700-06016=00 FLANSCHENSCHRAUBE, 6X16	4	4	4	4	4	4		

I 8

F-8

Front fork
(CB900Fz)

Fourche avant
(CB900Fz)

Vordergabel
(CB900Fz)

Horquilla delantera
(CB900Fz)

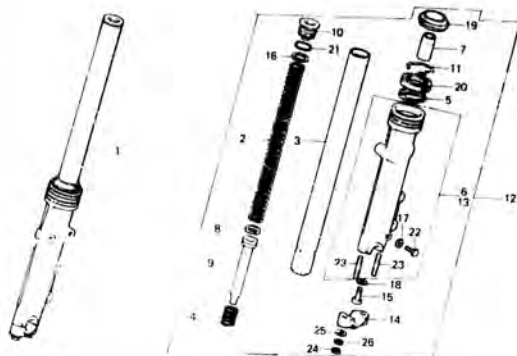

8436-18

Wartungspunkt	AP	Ref. Nr.	Teile-Nr.	Beschreibung	Menge				Serien-Nr.	Gebiets-Code
					Fz	Fa	Fa	Fz		
GABEL KOMPL., V. (JEWEILS 0,2 DAZUZAEHLEN.) FEDER, V., DAEMPFER GABELROHR KOMPL., V. (JEWEILS 0,4 DAZUZAEHLEN.) SIMMERRING, 35X48X11 (JEWEILS 0,4 DAZUZAEHLEN.)	0,5	1	51400-438-003	GABEL KOMPL., R. V.						
		2	51401-438-003	FEDER, V., DAEMPFER						
		3	51410-422-013	GABELROHR KOMPL., V.						
		4	51412-340-000	RUECKSCHLAGFEDER, V., GABEL						
		5	51412-422-003	FIXIERRING						
GEHAUSE KOMPL., UNTEN (JEWEILS 0,8 DAZUZAEHLEN.)	0,9	6	51421-438-003	GEHAUSE KOMPL., R. UNTEN						
		7	51432-371-003	DELSICHERUNGSSTUECK						
		8	51437-400-771	KOLBENRING						
		9	51440-423-003	ROHR, SITZ						
		10	51454-422-003	BOLZEN, V., GABEL						
		11	51466-375-000	ANSCHLAGRING, SIMMERRING						
		12	51500-438-003	GABEL KOMPL., L. V.						
		13	51521-438-003	GEHAUSE KOMPL., L. UNTEN						
		14	51634-410-003	ACHSHALTER, V., GABEL						
		15	90116-283-010	INNENSECHSKANTSCHRAUBE, 5MM						
		16	90504-425-003	SCHIBE, V., GABEL						

I 9

F-8

Front fork
(CB900Fz)

Fourche avant
(CB900Fz)

Vordergabel
(CB900Fz)

Horquilla delantera
(CB900Fz)

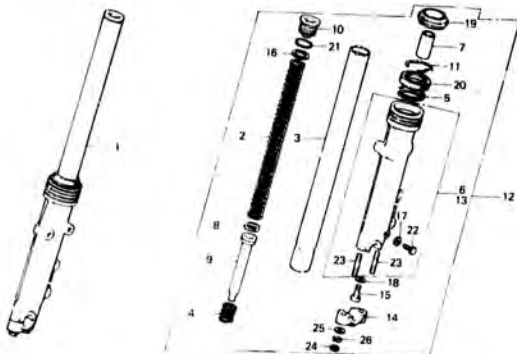

B438-18

Wartungspunkt	AP	Ref. Nr.	Teile-Nr.	Beschreibung	Menge				Serien-Nr.	Gebiets-Code
					CB900	Fz	Fa	Fz		
		17	90543-273-000	DICHTUNG, V. GABEL-ABLASSHAMM	2					
		18	90544-283-000	SPEZIALSCHEIBE, 8MM	2					
		19	91254-400-771	STAUBDICHTUNG, 35MM	2					
		20	91255-434-003	SIMMERRING, 35X48X11	2					
		21	91356-428-003	O-RING, 25,7X28	2					
		22	92000-06008	SCHRAUBE, HEX., 6X8	2					
		23	92700-08050-3B	STENBOLZEN, 8X50	4					
		24	94030-08000	MUTTER, HEX., 8MM	4					
		25	94101-08000	GLATTE SCHEIBE, 8MM	4					
		26	94111-08000	FEDERRING, 8MM	4					

I 10

F-8-1

Front fork
(CB900FA • Fb • F2b)

Fourche avant
(CB900FA • Fb • F2b)

Vordergabel
(CB900FA • Fb • F2b)

Horquilla delantero
(CB900FA • Fb • F2b)

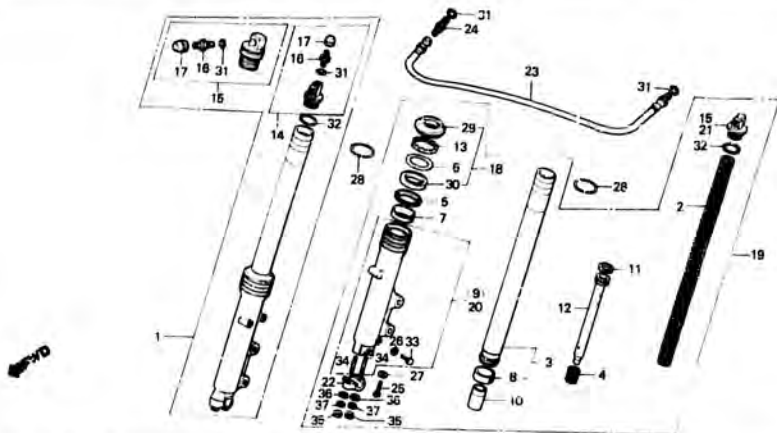

B438-59

Wartungspunkt	AP	Ref. Nr.	Teile-Nr.	Beschreibung	Menge				Serien-Nr.	Gebiets-Code
					Fz	Fa	Fc	F2c		
GABEL KOMPL., V. (Fa, F2b-AUSFUHRUNG 0.6) (JEWEL'S 0.2 DAZUZAEMLEN.)	0,3	1	51400-438-711	GABEL KOMPL., R. V. (SHOWA)	1				2110199	2110198
			51400-438-712	GABEL KOMPL., R. V. (SHOWA)	1					
FEDER, V. DAEMPFER	0,3	2	51400-438-731	GABEL KOMPL., R. V. (SHOWA)		1	1			
GABELROHR KOMPL., V. (Fa, F2b-AUSFUHRUNG 0.9)		0,8	3	51401-438-003	FEDER, V. DAEMPFER		2	2		
EINSCHL. DAZUGEHÖRIGER TEIL (JEWEL'S 0.5 DAZUZAEMLEN.)		4	51401-438-731	FEDER, V. DAEMPFER		2	2			
			51410-469-013	GABELROHR KOMPL., V. (SHOWA)		2	2			
GEHÄUSE KOMPL., UNTEN (Fa, F2b-AUSFUHRUNG 0.9) (JEWEL'S 0.5 DAZUZAEMLEN.)		5	51410-438-731	GABELROHR KOMPL., V. (SHOWA)		2	2			
			51412-340-000	RUECKSCHLAGFEDER, V. GABEL		2	2			
STÜTZRING, 35X48X11 (Fa, F2b-AUSFUHRUNG 0.9) (JEWEL'S 0.5 DAZUZAEMLEN.)		6	51416-461-003	RUECKSCHLAGFEDER		2	2			
			51412-422-003	FIXIERRING		2	2			
VERBINDUNGSSCHLAUCH KOMPL., V. GABEL	0,2	7	51413-469-003	STUETZSCHEIBE (SHOWA)		2				
			51413-461-003	STUETZSCHEIBE		2	2			
			51414-469-003	BUCHSE, FUEHRUNG (SHOWA)		2				

I 11

F-8-1

Front fork
(CB900FA • Fb • F2b)

Fourche avant
(CB900FA • Fb • F2b)

Vordergabel
(CB900FA • Fb • F2b)

Horquilla delantera
(CB900FA • Fb • F2b)

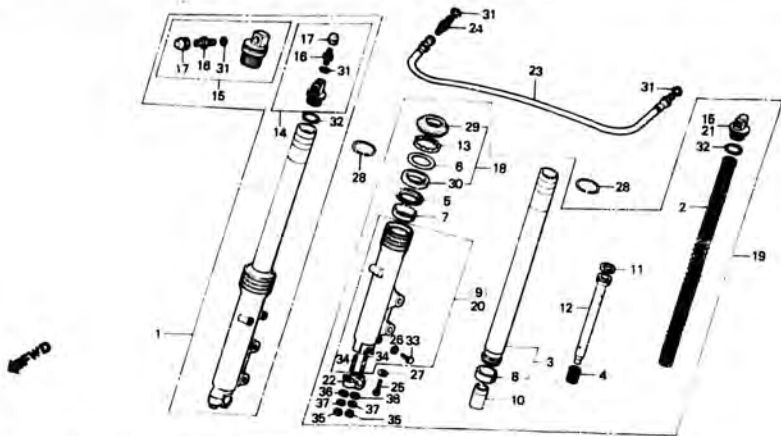

8438-53

Wartungspunkt	AP	Ref. Nr.	Teile-Nr.	Beschreibung	Menge				Serien-Nr.	Gebiets-Code
					Fz	Fa	Fz F2a	Fc F2c		
		8	51414-461-003	BUCHSE, FUHRUNG		2	2			
			51415-461-003	BUCHSE, SCHIEBER (SHOWA)		2	2			
		9	51415-461-003	BUCHSE, SCHIEBER		2	2			
			51421-469-003	GEHAUSE KOMPL., R. UNTEN (SHOWA)	1					
			51421-445-651	GEHAUSE KOMPL., R. UNTEN (SHOWA)		1	1			
		10	51432-371-003	DELSICHERUNGSSTUECK (SHOWA)	2					
			51432-461-771	DELSICHERUNGSSTUECK	2		2			
		11	51437-400-771	KOLBENRING	2					
			51437-461-003	KOLBENRING	2	2	2			
		12	51440-469-013	ROHR, SITZ (SHOWA)	2					
			51440-445-651	ROHR, SITZ (SHOWA)	2	2	2			
		13	51447-469-003	INNENSPIENGRING, 51,5	2					
			51447-461-003	INNENSPIENGRING, 50MM	2	2	2			
		14	51450-461-003	BEWEGLICHES ABTRIEBSFLAECHENSATZ	2		1			
		15	51454-469-003	BEWEGLICHES ABTRIEBSFLAECHENSATZ	2				2110198	

I 12

F-8-1

Front fork
(CB900FA • F8 • F2B)

Fourche avant
(CB900FA • F8 • F2B)

Vordergabel
(CB900FA • F8 • F2B)

Horquilla delantera
(CB900FA • F8 • F2B)

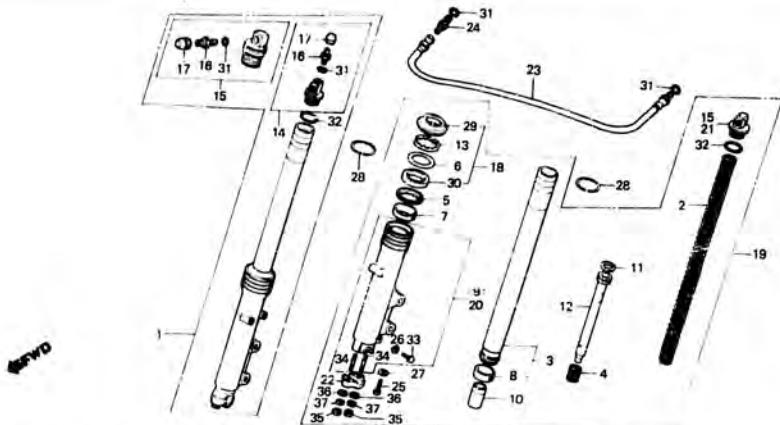

8438 56

Wartungspunkt	AP	Ref. Nr.	Teile-Nr.	Beschreibung	Menge				Serien-Nr.	Gebiets-Code
					Fz	Fx	Fa F2a	Fc F2c		
		51454-469-013		BEWEGLICHES ABTRIEBSFLAECHE SATZ (SHOWA)	2				2110199	
		16 51456-469-003		LUFTVENTIL KOMPL. (SHOWA)	2					2110198
		51456-469-013		LUFTVENTIL KOMPL. (SHOWA)	2				2110199	
		17 51457-469-000		KAPPE KOMPL., LUFTVENTIL	2	2	2			
		18 51490-434-305		DICHTUNG SATZ, V. GABEL	2	1	1			
		51490-461-770		DICHTUNG SATZ, V. GABEL	2	2	2			
		19 51500-438-711		GABEL KOMPL., L. V. (SHOWA)	1					2210198
		51500-438-712		GABEL KOMPL., L. V. (SHOWA)	1				2110199	
		51500-438-731		GABEL KOMPL., L. V. (SHOWA)	1	1	1			
		20 51521-469-003		GEHAEUSE KOMPL., L. UNTEN (SHOWA)	1					

I 13

F-8-1

Front fork
(CB900FA • F8 • F2B)

Fourche avant
(CB900FA • F8 • F2B)

Vordergabel
(CB900FA • F8 • F2B)

Horquilla delantera
(CB900FA • F8 • F2B)

RPWD

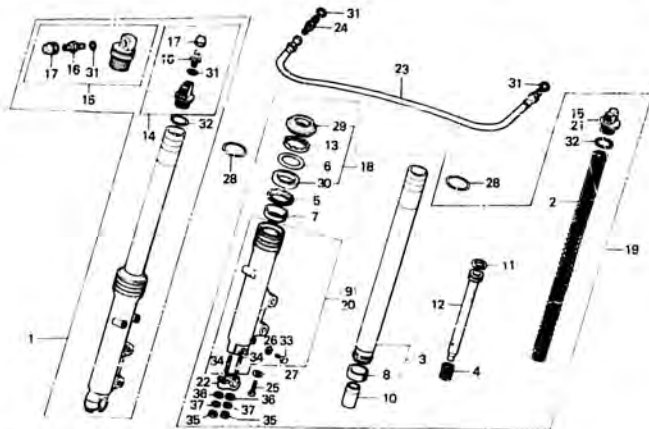

8438-59

Wartungspunkt	AP	Ref. Nr.	Teile-Nr.	B.schreibung	Menge				Serien-Nr.	Gebiets-Code
					Fz	Fa	F8	F2B		
		61571-631-631		GEHÄUSE KOMPL., L. UNTEN (SHOWA)	1	1				
		21	51355-461-003	SCHRAUBE, L, V. GABEL			1	1		
		22	51634-410-003	ACHSHALTER, V, GABEL			2	2	2	
		23	53137-438-731	VERBINDUNGSSCHLAUCH KGHPL., V. GABEL			1	1		
		24	53139-463-000	VERBINDUNG			1	1		
		25	90116-263-010	INNENSECHSKANTSCHRAUBE, 8MM			2	2	2	
		26	90543-273-000	DICHTUNG, V. GABEL-ABLASSHAHN			2	2	2	
		27	90944-283-000	SPEZIALSCHEIBE, 8MM			2	2	2	
		28	90601-469-000	SPRENGRING, 31,4MM			2	2		
			90601-438-730	SPRENGRING			2	2		
		29	91254-434-003	STAUBDICHTUNG, 35MM			2	2		
			91254-461-003	STAUBDICHTUNG, V. GABEL			2	2		
			91254-461-004	STAUBDICHTUNG, V. GABEL			2	2		
		30	91255-434-013	SIMMERRING, 35X48X11			2	2		

I 14

F-8-1

Front fork
(CB900FA • FB • F2B)

Fourche avant
(CB900FA • FB • F2B)

Vordergabel
(CB900FA • FB • F2B)

Horquilla delantera
(CB900FA • FE • F2B)

49W0

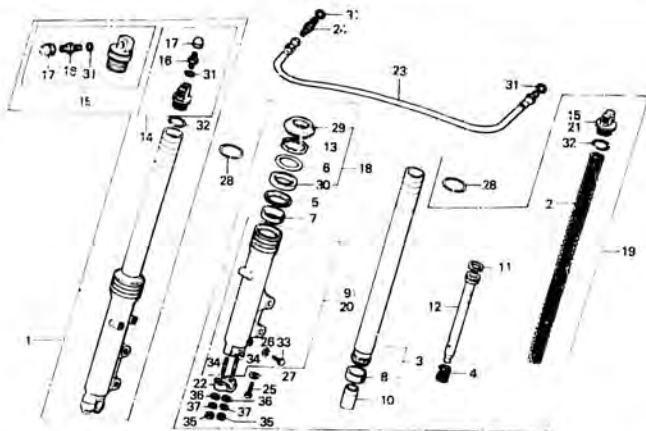

5416-53

Wartungspunkt	AP	Ref. Nr.	Teile-Nr.	Beschreibung	Menge				Serien-Nr.	Gebiets-Code
					Fz	Fa	Fa F2B	Fc F2C		
		31	91301-469-003	O-RING, 5,8X1,9		2				
		32	91356-628-003	O-RING, 25,7X2,8		2	3	3		
			91356-371-000	O-RING, 2,9X2,4		2	2	2		
		33	92000-06008	SCHRAUBE, HEX., 6X8		2	2	2		
		34	92700-08050-3B	STEMBOLZEN, 8X50		4	4	4		
		35	94030-08000	MUTTER, HEX., 8MM		4	4	4		
		36	94101-08000	GLATTE SCHNIBE, 8MM		4	4	4		
		37	94111-08000	FEDERRING, 8MM		4	4	4		

I 15

F-8-2

Front fork
(CB900Fc • F2c)

Fourche avant
(CB900Fc • F2c)

Vordergabel
(CB900Fc • F2c)

Horquilla delantera
(CB900Fc • F2c)

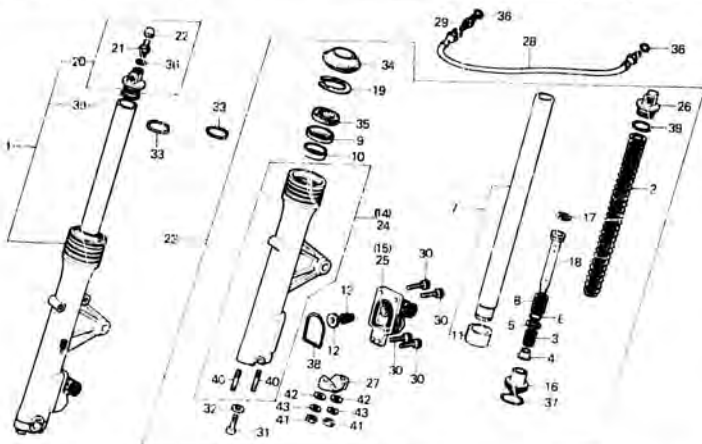

Wartungspunkt	AP	Ref. Nr.	Teile-Nr.	Beschreibung	Maße				Serien-Nr.	Gebiets-Code
					Fz	Fa	Fa	Fc		
GABEL KOMPL., V. (JEWEILS 0,2 DAZUZAEHLEN.)	0,6	1	51400-MB7-611	GABEL KOMPL., R. V.					1	1
FEDER, V. DAEMPFER	0,3	2	51401-MB7-611	FEDER, V. DAEMPFER					2	2
GABELROHR KOMPL., V. (JEWEILS 0,5 DAZUZAEHLEN.)	0,9	3	51402-MB7-611	FEDER OELSICHERUNG					2	2
GEHAEUSE KOMPL., UNTEN (JEWEILS 0,5 DAZUZAEHLEN.)		4	51403-MB7-611	VENTIL, OELSICHERUNG					2	2
SIMMERRING, 39X50X11 (JEWEILS 0,5 DAZUZAEHLEN.)		5	51404-MB7-611	FEDERSITZ					2	2
GEHAEUSE KOMPL., UNTEN (JEWEILS 0,3 DAZUZAEHLEN.)	0,5	6	51405-MB7-611	ANSCHLAGRING					4	4
VERBINDUNGSSCHLAUCH KOMPL., V. GABEL	0,2	7	51410-MB7-611	GABELROHR KOMPL., V.					2	2
		8	51411-463-003	RUECKSCHLAGFEDER, V. GABEL					2	2
		9	51412-463-003	FIXIERRING					2	2
		10	51414-463-003	BUCHSE, GABELROHR					2	2
		11	51415-463-003	BUCHSE, SCHIEBER					2	2
		12	51417-MC7-003	DICHTUNG					2	2
		13	51418-MC7-003	FEDER, KOLBEL					2	2
		14	51421-MB7-611	GEHAEUSE KOMPL., R. UNTEH					1	1

I 16

F-8-2

Front fork
(CB900Fc • F2c)

Fourche avant
(CB900Fc • F2c)

Vordergabel
(CB900Fc • F2c)

Horquilla delantera
(CB900Fc • F2c)

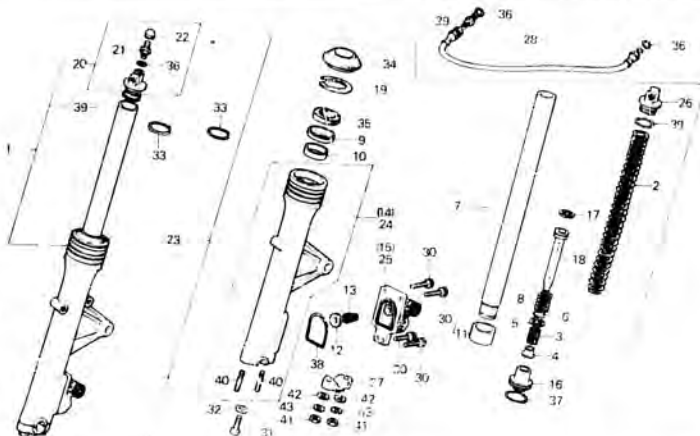

Wartungspunkt	AP	Ref. Nr.	Teile-Nr.	Beschreibung	Menge				Series-Nr.	Gebiets-Code
					F2	FA	Fc	F2c		
		16	51430-MB7-611	GEHAEUSE KOMPL., R. KOLBEN			1	1		
		16	51432-MB7-611	DELSICHERUNGSSTUECK			2	2		
		17	51437-463-003	KOLBENRING			4	4		
		18	51440-MB7-611	ROHR, SITZ			2	2		
		19	51447-463-003	INNENSPIRENDRING, 50			2	2		
		20	51450-MB7-611	BEWEGLICHES ABTRIEBSFLAECHE			1	1		
		21	51456-468-003	LUFTVENTIL KOMPL.			1	1		
		22	51457-468-000	KAPPE KOMPL., LUFTVENTIL			1	1		
		23	51500-MB7-611	GABEL KOMPL., L. V.			1	1		
		24	51521-MB7-611	GEHAEUSE KOMPL., L. UNTEN			1	1		
		25	51530-MB7-611	GEHAEUSE KOMPL., L. KOLBEN			1	1		
		26	51555-M67-611	SCHRAUBE, L. V. GABEL			1	1		
		27	51634-41C-003	ACHSHALTER, V. GABEL			2	2		

J 1

F-8-2

**Front fork
(CB900Fc - F2c)**

**Fourche avant
(CB900Fc - F2c)**

**Vordergabel
(CB900Fc - F2c)**

**Horquilla delantera
(CB900F - F2c)**

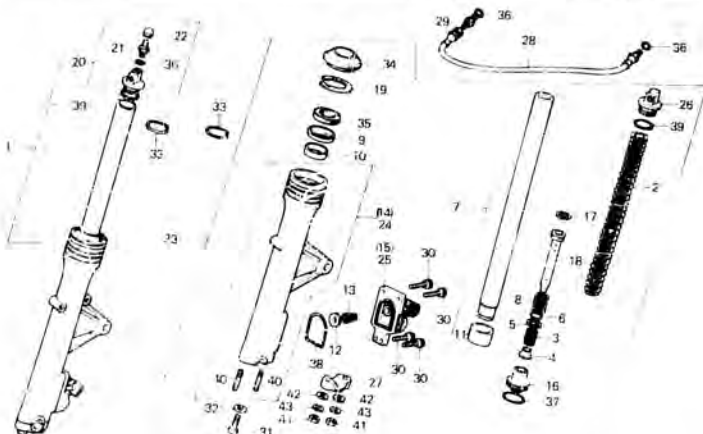

3196-111

Wartungspunkt	AP	Ref. Nr.	Teile-Nr.	Beschreibung	Menge			Serien Nr.	Gebiets-Code
					Fz	Fa	Fc/F2c		
		28	53137-MB7-011	VERBINDERSCHEIBE, KUMPL., V. GABEL	1		1		
		28	53139-460-840	VERBINDERSCHEIBE	1		1		
		30	90116-ML7-003	INHEXAGONKAPITZSCHRAUBE	2		0		
		31	90116-283-010	HEXAGONKAPITZSCHRAUBE, 8MM	2		2		
		32	90544-283-000	ALUSCHEIBE, 8MM	2		2		
		33	90601-438-730	SPRENGRING	2		2		
		34	91234-463-003	STAUBDICHTUNG	2		2		
		35	91235-463-003	REINIGER, 19450X11	2		2		
		33	91301-569-003	O-RING, 5,8X1,9	3		3		
		37	91302-MA3-6A1	O-RING, 14,8X1,9	2		2		
		36	91303-MC7-003	O-RING, 54,4X3,1	2		2		
		39	91354-463-003	O-RING, 29X1,3	2		2		
		40	82700-08050-3B	STEBHOLZEN, 8X50	4		4		
		41	94030-08000	MUTTER, HEX., 8MM	4		4		
		42	94101-08000	GLATTE SCHEIBE, 8MM	4		4		
		43	94111-08000	FEDERRING, 2MM	4		4		