

BLOCKINDEX - RAHMENGRUPPE

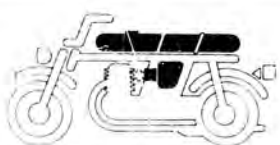
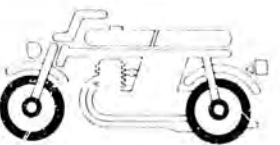
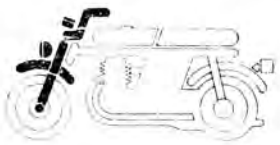

F 1	Scheinwerfer	G 2
F 2	Messer	G 6
F 3	Voltmeter Quarzröhre	J 2
F 4	Lenksägenpedale/Schalter Kabel	H 3
F 5	Vorderbremse-Hauptzylinder	H 7
F 6	Leuchte Oberer Brücke	H14
F 6	Steuerkopfschutz	I 2
F 7	Vorderer Kotflügel	I 5
F 8	Vordergabel	I 8

F 9	Vorderadbremsattel	J 2
F 10	Vorderrad	J11
F 11	Hinteradbrems-Hauptzylinder	K 2
F 12	Hinteradbremsattel	K 5
F 13	Hinterad	K11

F 14	Benzin-tank	L 4
F 15	Sitz	L10
F 16	Seiten- deckel Zünd- einheit Regler	L13
F 17	Batterie	M 7
F 18	Luft- filter	M 9

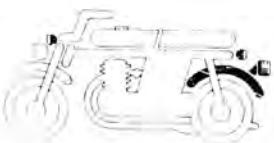

F 19	Auslauf- topf	M13
F 20	Bremse- tas- Schal- pedal	N 2
F 21	Tritt	N 4
F 22	Ständer	N14
F 23	Hinter- Schwin- ge Ket- tenschutz	N16
F 24	Hinterer Stoßdämpfer	2-C 5

F 25	Hinterer Kotflügel	2-C 8
F 26	Blinker	2-C10
F 27	Rockerschwert	2-D 5

F 28	Kabelbaum Zündspule	2-D 7
F 29	Rehmen	2-D10
F 30	Werkzeug	2-E 5
F 31	Verkleidung	2-E 7
F 32	Verkleidungs- stütze	2-E12
F 33	Verkleidungs- tasche	2-E16
F 34	Benzin- tank- Streifen	2-F 3
F 35	Merque Verkleidung	2-F 7
F 36	Merque Sei- ter- deckel	2-F 8
F 37	Seiten- deckel- Streifen	2-F 9
F 38	Hinterer verkleidungs- streifen	2-F11
F 39	Fuß- tabelle	2-F13

2-D7

F-28

Wire harness - Ignition coil

Faisceau électrique -
Bobine d'alkumage

Kabelbaum - Zündspule

Equipio de alambre -
Bobina de encendido

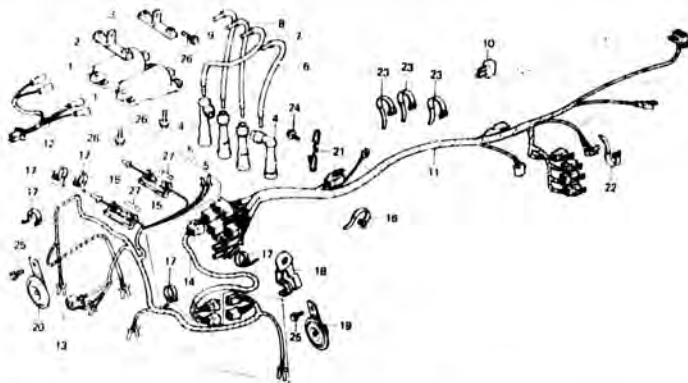

0130 10

Wartungspunkt	AP	Ref. Nr.	Teile-Nr.	Beschreibung	N° de requis C8900					N° de série	Code de zone	
					Fz	Fa	Fb	F2a	Fc			F2c
ZUENDSPULE KOMPL. (DIE GLEICHE ARBEITSZEIT- PAUSCHALE, AUCH WENN NUR EIN ODER ALLE TEILL GEWARTET WIRD HOCHSPANNUNGSSCHNUR (DIE GLEICHE ARBEITSZEIT- PAUSCHALE, AUCH WENN NUR EIN ODER ALLE TEILL GEWARTET WIRD HILFSKABELBAUM B SILIKONGLEICHRICHTER KOMPL. HILFSKABELBAUM A KABELBAUM HILFSKABELBAUM HUPE KOMPL.	0,3	1	30500-422-003	ZUENDSPULE KOMPL.	2	2	2	2				
				30500-422-013	ZUENDSPULE KOMPL.				2	2	2	2
				2	30501-425-000	STUETZE, ZUENDSPULE	1	1	1	1	1	1
				3	30502-425-770	STUETZE, ZUENDSPULE	1	1	1	1	1	1
				4	30501-425-000	STUE.ZE, ZUENDSPULE	1					
		4	30700-390-153	KAPPE KOMPL. C.	2	2	2	2	2	2		
		5	30710-405-153	KAPPE KOMPL. B.	2	2	2	2	2	2		
				GERAEUSCHSPERRE GERAEUSCHSPERRE								
	0,2	6	30751-425-000	HOCHSPANNUNGSSCHNUR (1-1)	1	1						
			30751-425-010	HOCHSPANNUNGSSCHNUR (1-1)			1	1	1	1		
	2,0	7	30752-425-000	HOCHSPANNUNGSSCHNUR (2-4)	1	1						
	0,3		30752-425-010	HOCHSPANNUNGSSCHNUR (2-4)			1	1	1	1		
	0,1	8	30753-425-000	HOCHSPANNUNGSSCHNUR (3-2)	1	1						
			30753-425-010	HOCHSPANNUNGSSCHNUR (3-2)			1	1	1	1		
		9	30754-425-000	HOCHSPANNUNGSSCHNUR (4-3)	1	1						
			30754-425-010	HOCHSPANNUNGSSCHNUR (4-3)			1	1	1	1		
		10	31700-124-003	SILIKONGLEICHRICHTER KOMPL. (STANLEY)	1	1	1	1	1	1		

2-D8

F-28

Wire harness - Ignition coil

Faisceau électrique -

Bobine d'allumage

Kabelbaum - Zündspule

Equipo de alambre -

Bobina de encendido

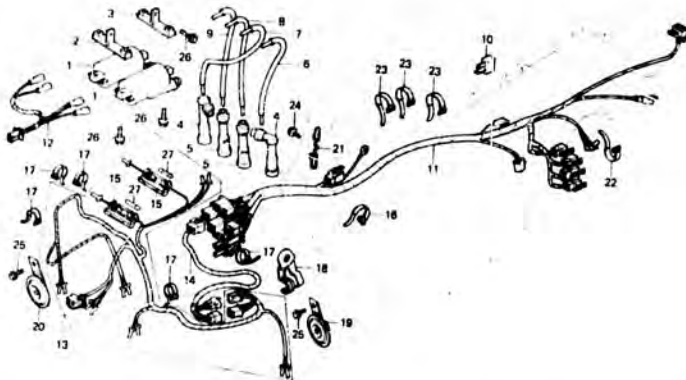

3438-44

Wartungspunkt	AP	Ref. Nr.	Teile-Nr.	Beschreibung	Menge					Serien-Nr.	Gebiets-Code	
					Fz	FA	Fa	F2a	Fc			F3c
			31700-124-008	SILIKONGLEICHRICHTER KOMPL. (SHINDGENGEN)	1	1	1	1	1	1		
		11	32100-438-000	KABELBAUM 32100-438-303	1							
			32100-438-303	KABELBAUM	1						2112922	2112921
			32100-438-010	KABELBAUM			1	1	1	1		
		12	32101-423-000	HILFSKABELBAUM A	1	1						
			32103-438-660	HILFSKABELBAUM A			1	1	1	1		
		13	32101-438-840	HILFSKABELBAUM			1					
			32101-MB7-700	HILFSKABELBAUM A					1	1		
			32102-438-840	HILFSKABELBAUM B					1			
		14	32102-MB7-700	HILFSKABELBAUM B						1		
			32125-463-770	GEHÄUSE, SICHERUNG (5A)			2			2		
		18	32161-367-690	DRAHTBAND	1							2000042

2-D9

F-28

Wire harness - Ignition coil

Faisceau électrique -
Bobine d'allumage

Kabelbaum - Zündspule

Equipo de alambre -
Bobina de encendido

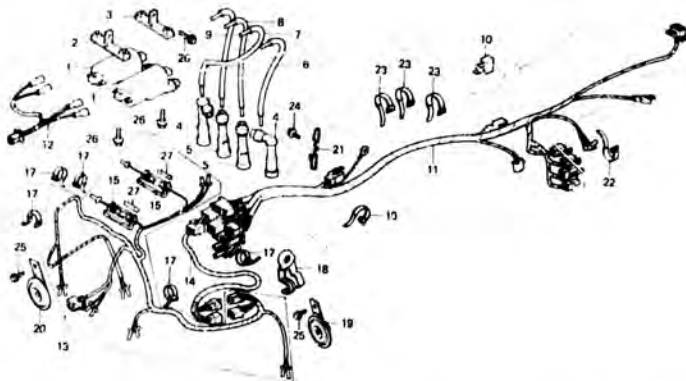

8436 44

Wartungspunkt	AP	Ref. Nr.	Teile-Nr.	Beschreibung	Menge				Serien-Nr.	Gebiets-Code
					C890	F2	FA	F2a		
			32161-438-000	DRAHTBAND	1				2000043	
		17	32161-404-000	DRAHTBAND B1		1	1	1	1	
		18	32174-438-000	HALTER, KABELBAUM	1	1				
			32174-MB7-810	HALTER, KABELBAUM						
		19	38110-438-004	HUPE KCHPL. (HIGH)			1		1	
			38110-438-801	HUPE KOMPL. (HIGH)			1		1	
		20	38120-438-004	HUPE KOMPL. (LOW)			1		1	
			38120-438-801	HUPE KOMPL. (LOW)			1		1	
		21	50174-438-000	FUEHRUNG, KABELBAUM		1	1	1	1	
		22	95014-61100	DRAHTBAND A1		1	1	1	1	
		23	95014-61200	DRAHTBAND A2		3	3			
		24	95700-06010-07	FLANSCHENSCHRAUBE, 6x10			4	4	4	
		25	95700-06012-00	FLANSCHENSCHRAUBE, 6x12			1	1	1	
							2		2	
		26	95700-06020-00	FLANSCHENSCHRAUBE, 6x20		6	6	6	6	
		27	98200-20500	SICHERUNG B (5A)			4		4	

DK, DM, SA, U
E, ED, F, C
DK, DM, SA, U
E, ED, F, G

2-D10

F-29

Frame body (CB900Fz • FA • Fb • F2b)
(Oil cooler • CB900Fb • F2b)

Cadre (CB900Fz • FA • Fb • F2b)
(Radiateur d'huile • CB900Fb • F2b)

Rahmen (CB900Fz • FA • Fb • F2b)
(Ölkühler • CB900Fb • F2b)

Cuerpo de cuadro (CB900Fz • FA • Fb • F2b)
(Enfriador de aceite • CB900Fb • F2b)

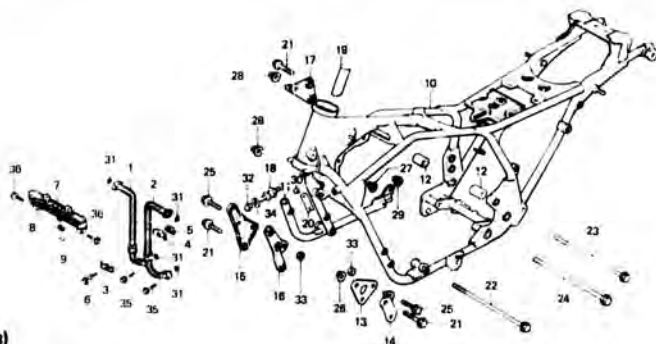

8438 - 05

Wartungspunkt	AP	Ref. Nr.	Teile-Nr.	Beschreibung	Menge				Serien-Nr.	Gebiets-Code
					CB900	Fz	Fa	Fc		
DELSCHLAUCH KOMPL., R. (JEWEILS 0,0 DAZUZÄHLEN.)	0,3	1	15510-438-000	DELSCHLAUCH KOMPL., R.						
DELKUEHLER KOMPL.		2	15515-438-000	DELSCHLAUCH KOMPL., L.						
KÖRPER KOMPL., RAHMEN	*8.7 (=9.0)	3	15526-438-000	HALTER A, DELSCHLAUCH						
VERBINDUNGSRÖHR	0,6	4	15527-438-000	HALTER B, DELSCHLAUCH						
O-RING, 15x2,5 (WENN DIE KOMPL. EINHEIT GEWARTET WIRD, BETRÄGT DIE ARBEITSZEIT-PAUSCHALE 0,2)	0,1	5	15528-438-000	HALTER C, DELSCHLAUCH						
		6	15529-438-000	HALTESCHRAUBE, DELSCHLAUCH						
		7	15600-438-003	DELKUEHLER KOMPL.						
		8	15617-438-000	FESTSTELLGUMMI, DELKUELER						
		9	15618-438-000	FESTSTELLSTIFT, DELKUEHLER						
		10	50100-438-000ZA	KÖRPER KOMPL., RAHMEN *NH-1*	1					E,ED,F,G
			50100-438-650ZA	KÖRPER KOMPL., RAHMEN *NH-1*	1					U
			50100-438-680ZA	KÖRPER KOMPL., RAHMEN *NH-1*	1					DK,DM,SA
			50100-438-010ZA	KÖRPER KOMPL., RAHMEN *NH-1*		1				E,ED,F,G
			50100-438-651ZA	KÖRPER KOMPL., RAHMEN *NH-1*		1				2102490
			20100-438-652ZA							2104160
			50100-438-661ZA	KÖRPER KOMPL., RAHMEN *NH-1*		1				U
			50100-438-682ZA							2104000
										DK,DM,SA

(1): Fz2 TYP

2-D11

F-29

Frame body (CB900Fz · FA · Fb · F2b)
(Oil cooler · CB900Fb · F2b)

Cadre (CB900Fz · FA · Fb · F2b)
(Radiateur d'huile · CB900Fb · F2b)

Rahmen (CB900Fz · FA · Fb · F2b)
(Ölkühler · CB900Fb · F2b)

Cuerpo de cuadro (CB900Fz · FA · Fb · F2b)
(Enfriador de aceite · CB900Fb · F2b)

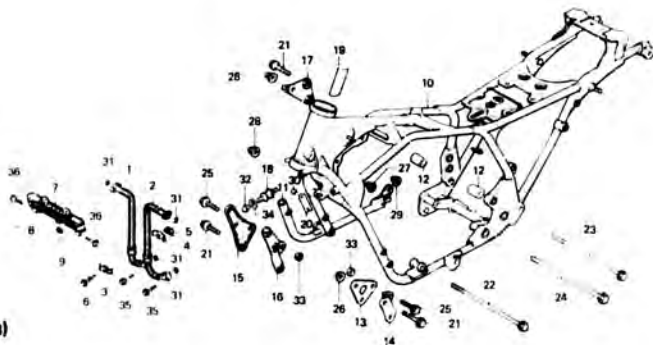

6438 / 41

Wartungspunkt	AP	Ref. Nr.	Teil-Nr.	Beschreibung	Menge CB900				Serien-Nr.	Gebiets-Code
					Fz	Fa	Fu	Fc F2c		
			50100-438-0202A	KOERPER KOMPL., RAHMEN »NH-1«	1				2102491	E, ED, F, G
			50100-438-6522A	KOERPER KOMPL., RAHMEN »NH-1«	1				2104161	U
			50100-438-6822A	KOERPER KOMPL., RAHMEN »NH-1«	1				2104001	DK, DM, SA
			50100-438-6302A	KOERPER KOMPL., RAHMEN »NH-1«		1	1			U
			50100-438-6302B	KOERPER KOMPL., RAHMEN »R-110«			1			U
			50100-438-6602A	KOERPER KOMPL., RAHMEN »NH-1«		1	1			E, F
			50100-438-6602B	KOERPER KOMPL., RAHMEN »R-110«			1			E, F
			50100-438-7302A	KOERPER KOMPL., RAHMEN »NH-1«		1	1			ED, G
			50200-438-7302B	KOERPER KOMPL., RAHMEN »R-110«			1			ED, G
			50100-438-7702A	KOERPER KOMPL., RAHMEN »NH-1«		1	1			DK, DM, SA
			50100-438-7702B	KOERPER KOMPL., RAHMEN »R-110«			1			DK, DM, SA
		11	50122-425-020	VERBINDUNGSROHR	1	1				
			50122-425-0202A	VERBINDUNGSROHR »NH-1«			1	1		
			50122-425-0202B	VERBINDUNGSROHR »R-110«				1		
		12	50327-425-000	BEFESTIGUNGSHULSE, A, MOTOR	2	2	2	2		

2-D12

F-29

Frame body (CB900Fz · FA · Fb · F2b)
(Oil cooler · CB900Fs · F2b)

Cadre (CB900Fz · FA · Fb · F2b)
(Radiateur d'huile · CB900Fs · F2b)

Rahmen (CB900Fz · FA · Fb · F2b)
(Ölkühler · CB900Fs · F2b)

Cuerpo de cuadro (CB900Fz · FA · Fb · F2b)
(Enfriador de aceite · CB900Fs · F2b)

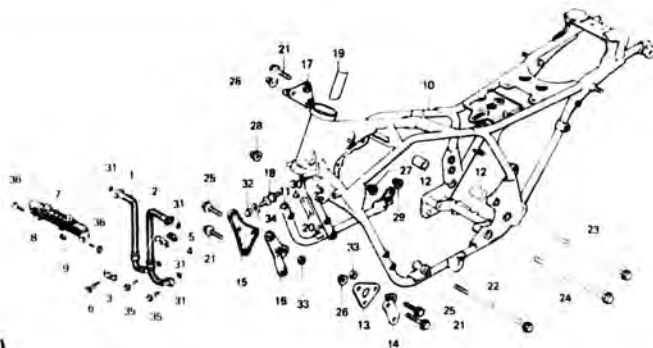

94 01 01

Wartungspunkt	AP	Ref. Nr.	Teile-Nr.	Beschreibung	Menge			Serien Nr.	Gebiets-Code
					Fz	Fa	Fb		
		13	50351-438-000	MOTORAUFHAENGUNGSPLATTE, V.	1	1			
			50351-438-000ZA	MOTORAUFHAENGUNGSPLATTE, V.		1	1		
				NH-1					
			50351-438-000ZB	MOTORAUFHAENGUNGSPLATTE, V.			1		
				R-110					
	1A	13	50352-438-000	MOTORAUFHAENGUNGSPLATTE, L. V.	1	1			
			50352-438-000ZA	MOTORAUFHAENGUNGSPLATTE, L. V.		1	1		
				NH-1					
			50352-438-000ZB	MOTORAUFHAENGUNGSPLATTE, L. V.			1		
				R-110					
	15	13	50353-438-000	AUFHAENGUNGSPLATTE B, MOTOR	1	1			
			50353-438-000ZA	AUFHAENGUNGSPLATTE B, MOTOR		1	1		
				NH-1					
			50353-438-000ZB	AUFHAENGUNGSPLATTE B, MOTOR			1		
				R-110					
	16		50354-438-000	AUFHAENGUNGSPLATTE A, MOTOR	1				

2-D13

F-29

Frame body (CB900Fz • FA • Fb • F2b)
(Oil cooler • CB900Fb • F2b)

Cadre (CB900Fz • FA • Fb • F2b)
(Radiateur d'huile • CB900Fb • F2b)

Rahmen (CB900Fz • FA • Fb • F2b)
(Ölkühler • CB900Fb • F2b)

Cuerpo de cuadro (CB900Fz • FA • Fb • F2b)
(Enfriador de aceite • CB900Fb • F2b)

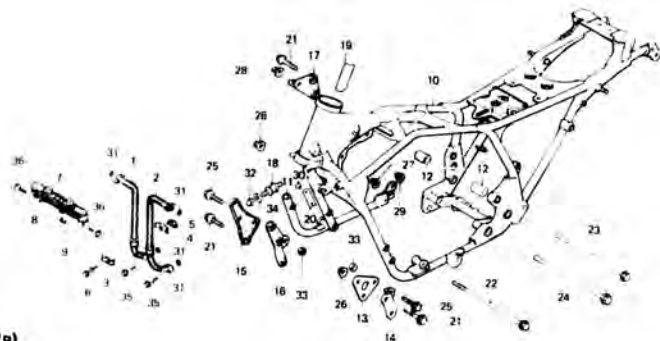

H438-45

Wartungspunkt	AP	Ref. Nr.	Teile-Nr.	Beschreibung	Menge				Serien-Nr.	Gebiets-Code
					Fz	Fa	Fb	Fc		
		50354-438-010	50354-438-010ZA	AUFHÄNGUNGSPLATTE A, MOTOR	1					
		50354-438-010ZA	50354-438-010ZA	AUFHÄNGUNGSPLATTE A, MOTOR		1	1			
		50154-438-010ZB	50154-438-010ZB	AUFHÄNGUNGSPLATTE A, MOTOR			1			
		50356-425-010	50356-425-010ZA	BUEGEL, H. MOTORAUFHÄNGER	1	1				
		50356-425-020ZA	50356-425-020ZA	BUEGEL, H. MOTORAUFHÄNGER		1	1			
		50356-425-020ZB	50356-425-020ZB	BUEGEL, H. MOTORAUFHÄNGER			1			
		85201-438-000	85201-438-000	HALTEGUMMI, DELKUEHLER	2	2	2	2		
		87125-041-680	87125-041-680	TYPENSCHILD	1	1	1	1		
		87201-438-611	87201-438-611	EINGESCHRIEBENES NUMMERSCHILD	1	1	1	1		DK, DM, SA
		87501-438-730	87501-438-730	EINGESCHRIEBENES NUMMERSCHILD			1	1		1, ED, F, G
		21	90016-438-000	SPEZIALFLANSCHSCHRAUBE, 8X62	7	7	7	7		2, ED, F, G

2-D14

F-29

Frame body (CB900Fz · FA · Fb · F2b)
(Oil cooler · CB900Fb · F2b)

Cadre (CB900r z · FA · Fb · F2b)
(Radiateur d'huile · CB900Fb · F2b)

Rahmen (CB900Fz · FA · Fb · F2b)
(Ölkühler · CB900Fb · F2b)

Cuerpo de cuadro (CB900Fz · FA · Fb · F2b)
(Enfriador de aceite · CB900Fb · F2b)

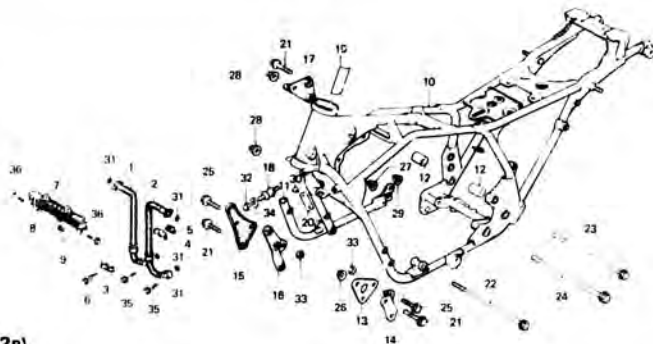

R438-05

Wartungspunkt	AP	Ref. Nr.	Teile-Nr.	Beschreibung	Menge				Serien-Nr.	Gebiets-Code
					CB900Fz	Fa	Fb	F2b		
		22	90152-438-000	AUFHAENGUNGSSCHLAUBE, MOTOR, 10X325	1	1	1	1		
		23	90156-438-000	AUFHAENGUNGSSCHLAUBE, MOTOR, 10X280	1	1	1	1		
		24	90157-438-000	AUFHAENGUNGSSCHLAUBE, MOTOR UNTEN, 12X363	1	1	1	1		
		25	90158-438-000	SPEZIALFLANSCHSCHRAUBE, 10X50	2					
			90159-438-000	SPEZIALFLANSCHSCHRAUBE, 10X60	2	2	2	2		
		26	90202-425-870	FLANSCHMUTTER, 8MM	2	2	2	2		
		27	90208-438-000	FLANSCHMUTTER, 8MM	2	2	2	2		
		28	90210-438-000	FLANSCHMUTTER, 10MM	2	2	2	2		
		29	90212-438-000	FLANSCHMUTTER, 12MM	1	1	1	1		
		30	90041-001-000	NIETSCHRAUBE, 1,5X5	2	2	2	2		F, ED, F, G
		31	91302-028-000	O-RING, 15X2,5			4	4		
		32	94021-06070	MUTTER, 6MM	2	2	2	2		
		33	94030-10000	MUTTER, HEX., 10MM	2	2	2	2		
		34	94101-06700	GLATTE SCHEIBE, 6MM	2	2	2	2		

2-D15

F-29

Frame body (CB900Fz • FA • Fb • F2b)
(Oil cooler • CB900Fb • F2b)

Cadre (CB900Fz • FA • Fb • F2b)
(Radiateur d'huile • CB900Fb • F2b)

Rahmen (CB900Fz • FA • Fb • F2b)
(Ölkühler • CB900Fb • F2b)

Cuerpo de cuadro (CB900Fz • FA • Fb • F2b)
(Enfriador de aceite • CB900Fb • F2b)

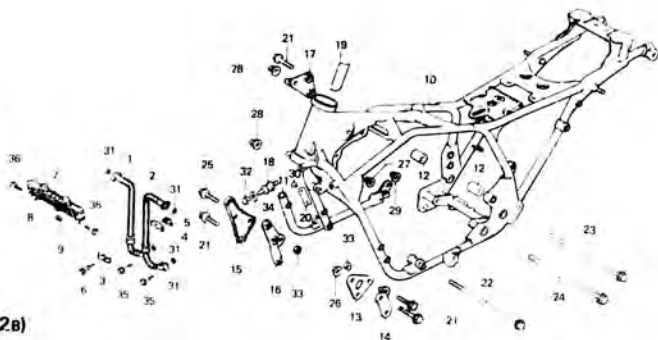

9139 45

Wertungspunkt	AP	Ref. Nr.	Teile-Nr.	Beschreibung	Menge				Serien-Nr.	Gebiets-Code
					Fz	Fa	Fb	F2b		
		35	96700-06025-00	FLANSCHENSCHRAUBE, 6x25		4	4			
		36	96000-06035-00	FLANSCHENSCHRAUBE, 6x35		4	4			

2-D16

F-29-1

Frame body (CB900Fc - F2c)
(Oil cooler)

Cadre (CB900Fc - F2c)
(Radiateur d'huile)

Rahmen (CB900Fc - F2c)
(Ölkühler)

Cuerpo de cuadro (CB900Fc - F2c)
(Enfriador de aceite)

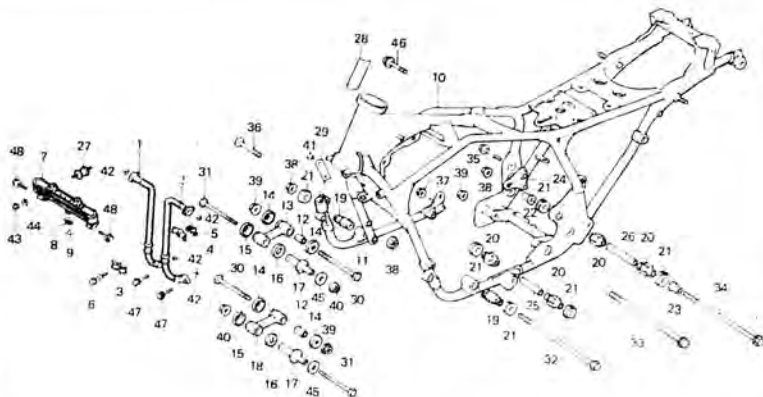

Wartungspunkt	AP	Ref. Nr.	Teile-Nr.	Beschreibung	Menge				Serien-Nr.	Gebiets-Code
					CB900	Fz	Fa	Fm F2a Fc F2c		
DELSCHLAUCH KOMPL. (JEWEILS G1 DARZUZAEBLEN.)	0,3	1	15510-438-000	DELSCHLAUCH KOMPL., R.				1	1	
		2	15515-438-000	DELSCHLAUCH KOMPL., L.				1	1	
DELKUEHLER KOMPL.		3	15526-438-000	HALTER A, DELSCHLAUCH				1	1	
KOERPER KOMPL., RAHMEN	*B.7 (*9.0)	4	15527-438-000	HALTER B, DELSCHLAUCH				1	1	
VERBINDERSDRHR	0,6	5	15528-438-000	HALTER C, DELSCHLAUCH				1	1	
		6	15529-438-000	HALTESCHRAUBE, DELSCHLAUCH				1	1	
	(): F2c TYP	7	15600-438-003	DELKUEHLER KOMPL.				1	1	
		8	15617-438-000	FESTSTELLGUMMI, DELKUELER				1	1	
		9	15618-438-000	FESTSTELLSTIFT, DELKUEHLER				1	1	
		10	50100-MB7-6002A	KOERPER KOMPL., RAHMEN *NH-1*				1	1	E, F
			50100-MB7-6002B	KOERPER KOMPL., RAHMEN *R-110*				1	1	E, F
			50100-M37-6102A	KOERPER KOMPL., RAHMEN *NH-1*				1	1	ED-G
			50100-MB7-6102B	KOERPER KOMPL., RAHMEN *R-110*				1	1	ED-G
			50100-MB7-6502A	KOERPER KOMPL., RAHMEN *NH-1*				3	1	U

2-E1

F-29-1

Frame body (CB900Fc • F2c)
(Oil cooler)

Cadre (CB900Fc • F2c)
(Radiateur d'huile)

Rahmen (CB900Fc • F2c)
(Ölkühler)

Cuerpo da cuadro (CB900Fc • F2c)
(Enfriador de aceite)

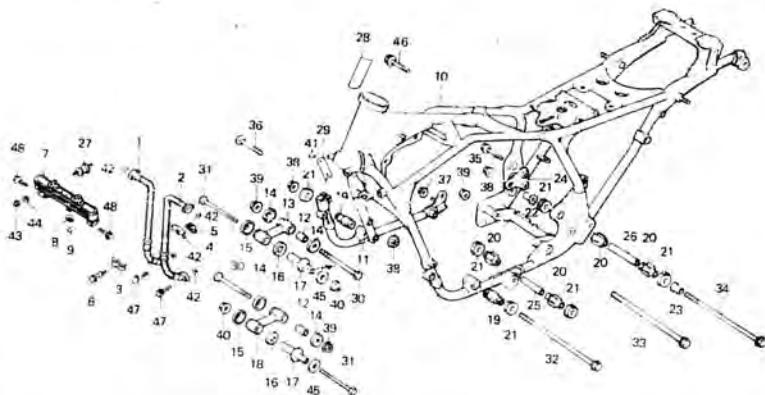

8738-10-2

Wartungspunkt	AP	Ref. Nr.	Teile-Nr.	Beschreibung	Messung				Serien-Nr.	Gebiets-Code
					1	Fa	Fb	Fc		
			50100-MB7-6502B	KOERPER KOMPL., RAHMEN *R-110*						
			50100-MB7-6802A	KOERPER KOMPL., RAHMEN *NH-1*						U DK-DH, SA
		11	50122-438-6702A	VERBINDUNGSROHR *R-110*						1 1
			50122-438-6702B	VERBINDUNGSROHR *NH-1*						1 1
		12	50184-438-670	HUELSE, STANGENZAPFEN						2 2
		13	50185-438-670	SPANNSTANGE KOMPL., R.						1 1
		14	50186-438-670	SCHEIBE, STANGENZAPFEN						4 4
		15	50188-438-670	SCHEIBE B, ZAPFEN						2 2
		16	50189-438-670	SCHEIBE C, ZAPFEN						2 2
		17	50191-438-670	HUELSE B, ZAPFEN						2 2
		18	50195-438-670	SPANNSTANGE KOMPL., L.						1 1
		19	50201-438-670	BEFESTIGUNGSGUMMI A						2 2

2-E2

F-29-1

Frame body (CB900Fc - F2c)
(Oil cooler)

Cadre (CB900Fc - F2c)
(Radiateur d'huile)

Rehnen (CB900Fc - F2c)
(Ölkühler)

Cuerpo de cuadro (CB900Fc - F2c)
(Enfriador de aceite)

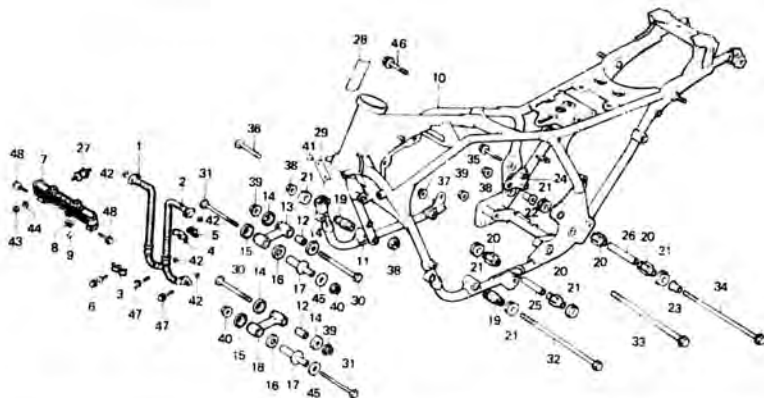

B422-105A

Wartungspunkt	AP	Ref. Nr.	Teile-Nr.	Beschreibung	Menge				Serien-Nr.	Gebiets-Code
					F2	Fx	F2c	F2c		
		20	50201-461-000	BEFESTIGUNGSGUMMI A, MOTOR			4	4		
		21	50203-461-000	BEFESTIGUNGSGUMMI C, MOTOR			6	6		
		22	50327-438-670	BEFESTIGUNGSHUELSE, R, MOTOR			1	1		
		23	50337-438-670	BEFESTIGUNGSHUELSE, L, MOTOR			1	1		
		24	50356-438-670ZA	BUEGEL, H, MOTORAUFHAENGER			1	1		
			50356-438-670ZB	BUEGEL, H, MOTORAUFHAENGER			1	1		*R-110*
		25	50362-438-670	WISTANZHUELSE B			1	1		*NH-1*
		25	50363-438-670	DISTANZHUELSE C			1	1		
		27	55201-438-000	HALTEGUMMI, ÖLKUEHLER			2	2		
		28	47125-041-680	TYPENSCHILD			1	1		
		29	87501-MB7-610	EINGESCHRIEBENES NUMMERSCHILD			1	1		DK, DM, SA E, ED, F, G

2-E3

F-29-1

Frame body (CB900Fc - F2c)
(Oil cooler)

Cadre (CB900Fc - F2c)
(Radiateur d'huile)

Rahmen (CB900Fc - F2c)
(Ölkühler)

Cuerpo de cuadro (CB900Fc - F2c)
(Enfriador de aceite)

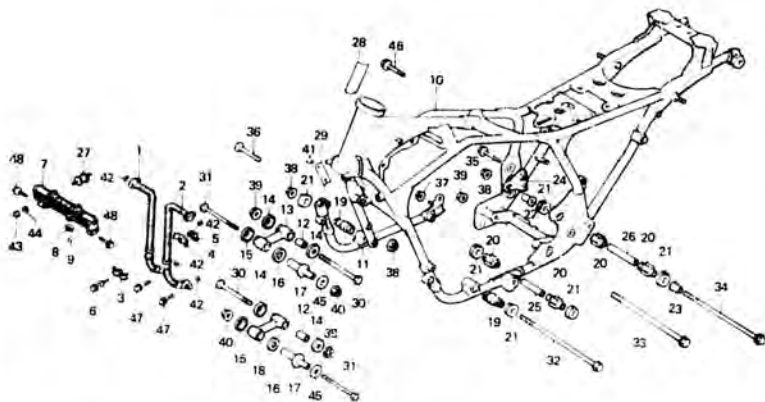

B438-106A

Wartungspunkt	AP	Ref. Nr.	Teile-Nr.	Beschreibung	Menge				Serien-Nr.	Gebiets-Code
					CB900	F2c	F2c	F2c		
					Fr	Fa	F1	F2c	F2c	
		33	90017-43B-670	SCHRAUBE, HEX., 10X80					2	2
		31	90154-MB7-610	SPEZIALFLANSCHSCHRAUBE, 8X70					2	2
		32	90155-MB7-610	AUFHÄNGUNGSSCHLAUBE, MOTOR, 10X34 ⁴					1	1
		33	90157-MB1-610	AUFHÄNGUNGSSCHLAUBE, MOTOR, 10X36 ⁵					1	1
		34	90162-MA3-660	SPEZIALFLANSCHSCHRAUBE, 10X28 ²					1	1
		35	90165-MA3-660	SPEZIALFLANSCHSCHRAUBE, 8X61					2	2
		36	90176-422-000	SPEZIALFLANSCHSCHRAUBE, 10X50					1	1
		37	90208-433-000	FLANSCHMUTTER, 8MM					2	2
		38	90210-438-000	FLANSCHMUTTER, 10MM					1	3
		39	90304-GA6-003	ACHSMUTTER					3	3
		40	90307-428-731	FLANSCHMUTTER, 8MM					2	2

2-E4

F-29-1

Frame body (CB900Fc - F2c)
(Oil cooler)

Cadre (CB900Fc - F2c)
(Radiateur d'huile)

Corpo de cuadro (CB900Fc - F2c)
(r)

Cuadro de cuadro (CB900Fc - F2c)
(Enfriador de aceite)

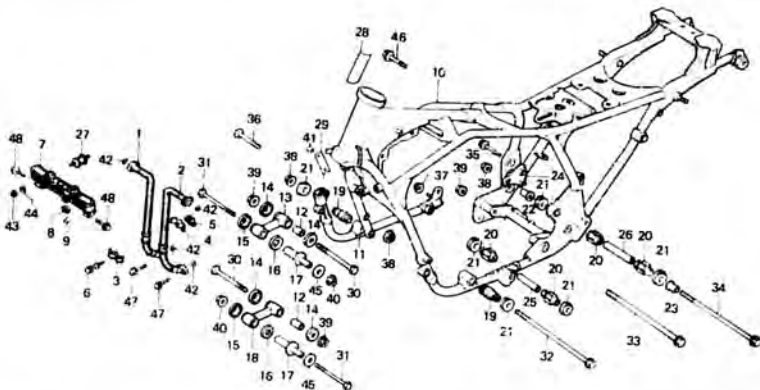

8428-105A

Wartungspunkt	AP	Ref. Nr.	Teile-Nr.	Beschreibung	Menge				Serien-Nr.	Gebiets-Code
					Fz	Fa	Fa	F2c		
		41	90641-001-000	NIETSCHRAUBE, 1,5x5			2	2		E,Ed,F,c
		42	91302-028-000	D-RING, 15x2,5			4	4		
		43	94021-06070	MUTTER, 6MM			2	2		
		44	94101-06700	GLATTE SCHEIBE, 6MM			2	2		
		45	94103-08200	GLATTE SCHEIBE, 8MM			2	2		
		46	95700-08022-00	FLANSCHENSCHRAUBE, 8x22			1	1		
		47	96000-06025-00	FLANSCHENSCHRAUBE, 6x25			4	4		
		48	96000-06035-00	FLANSCHENSCHRAUBE, 6x35			4	4		

2-E5

F-30

Tool

Outils

Werkzeug

Herramientas

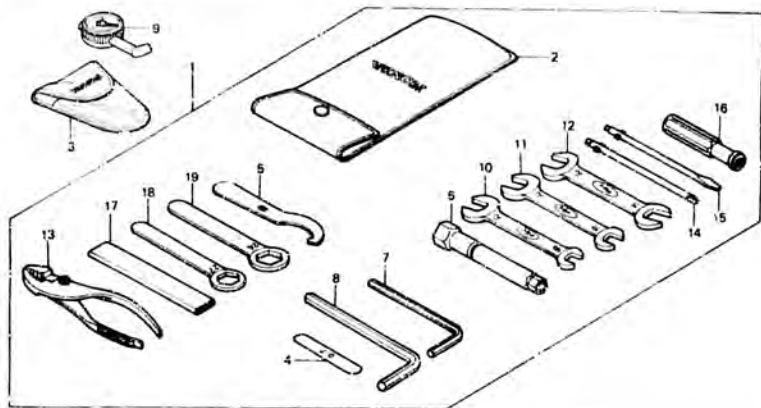

B438-294

Wartungspunkt	AP	Ref. Nr.	Teile-Nr	Beschreibung	Mengem.				Serien-Nr.	Gebiets-Code
					Fz	Fa	F2a	Fc		
		1	89010-438-000	WERKZEUG SATZ	1	1	1	1	1	
		2	89101-300-010	WERKZEUGTASCHE	1	1	1	1	1	
		3	89102-469-003	TASCHE, LUFTDRUCKMESSER	1	1	1	1	1	
		4	89103-371-000	FUEHLERLEHRE, 0,7	1	1	1	1	1	
		5	49215-404-670	STIFTSCHLUESSEL	1	1	1	1	1	
		6	89215-438-000	SCHLUESSEL, ZUENOKERZE	1	1	1	1	1	
		7	89221-371-000	SCHLUESSEL, HEX., 6MM	1	1	1	1	1	
		8	89222-371-000	SCHLUESSEL, HEX., 8MM	1	1	1	1	1	
		9	89301-460-003	DRUCKMESSER, LUFT	1					2103713
		9	89301-469-013	DRUCKMESSER, LUFT (KOMA)	1					2111700
		9	89301-461-003	DRUCKMESSER, LUFT	1					2112060
		9	89301-469-611	DRUCKMESSER, LUFT	1	1	1	1	1	2103713
		9	89301-469-661	DRUCKMESSER, LUFT	1	1	1	1	1	2111701
		10	99001-08120	SCHLUESSEL, 8X12	1	1	1	1	1	2112061
					1	1	1	1	1	2112326
										DK, DM, E, ED, F, U
										G
										SA

2-E6

F-30

Tool

Outils

Werkzeug

Herramientas

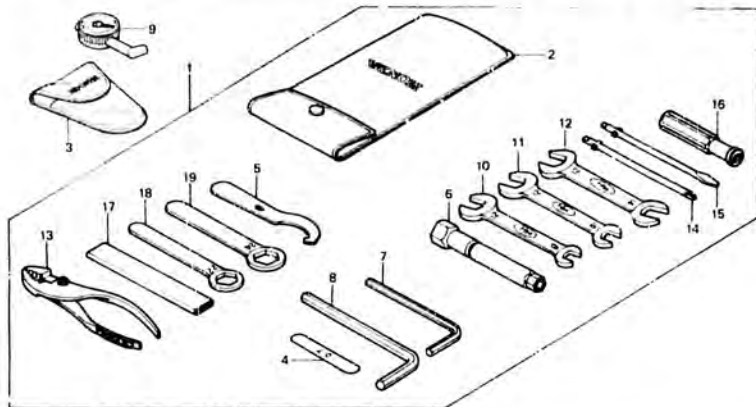

94 30 (10)

Wartungspunkt	AP	Ref. Nr.	Teile-Nr.	Beschreibung	Menge					Serien-Nr.	Gebiets-Code	
					Fz	Fa	Fa	F2a	Fc			F2c
		11	99001-10120	SCHLUESSEL, 10X12	1	1	1	1	1	1		
		12	99001-14170	SCHLUESSEL, 14X17	1	1	1	1	1	1		
		13	99002-13900	ZANGE, 135	1	1	1	1	1	1		
		14	99003-10000	KREUZSCHLITZSCHRAUBENZIEHER 2	1	1	1	1	1	1		
		15	99003-30000	MINUSSCHRAUBENZIEHER 2	1	1	1	1	1	1		
		16	99003-90000	GRIF	1	1	1	1	1	1		
		17	99006-12000	SCHLUESSELNEBEL, 120MM	1	1	1	1	1	1		
		18	99006-22000	SCHRAUBENSCHLUESSEL, 22MM	1	1	1	1	1	1		
		19	99006-24000	SCHRAUBENSCHLUESSEL, 24MM	1	1	1	1	1	1		

2-E7

F-31

Fairing
(CB900F2a • F2c)

Profilage
(CB900F2a • F2c)

Verkleidung
(CB900F2a • F2c)

Carena
(CB900F2a • F2c)

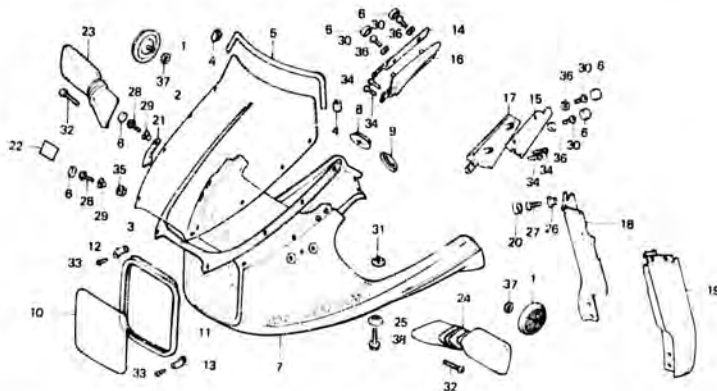

84/91

Wartungspunkt	AP	Ref. Nr.	Teile-Nr.	Beschreibung	Menge				Serien-Nr.	Gebiets-Code
					CB900	F2a	F2b	F2c		
WINDSCHEIBE GUMMI, SCHEINWERFERSCHILD POSTEN KORPER, VERKLEIDUNG SCHILD, SCHEINWERFER BEINSCHILD	0,2	1	37741-413-003	REFLEKTOR, V. (STANLEY)			2	2	DK, DM, E, ED, SA, U	
		2	64100-MA2-000	WINDSCHEIBE			1	1		
		3	64101-MA2-000	GUMMI, SCHEIBENBASIS			1	1		
		4	64102-438-850	SCHWEMME, SCHEIBENLEISTE			2	2		
		5	64105-438-850	LEISTE, WINDSCHEIBE			1	1		
	0,5	6	64109-438-850	KAPPE			4	8		
		7	64200-438-850ZA	KORPER, VERKLEIDUNG *R-110*			1	1		
			64200-438-850ZB	KORPER, VERKLEIDUNG *R-110H-U*			1	1		
		8	64218-MA2-000	GUMMITUELLE, SCHEINWERFER-SCHNUR			1	1		
		9	64219-MA2-000	STOEPSSEL, SCHEINWERFERGEHAEUSE			1	1		
		10	84220-438-850	SCHILD, SCHEINWERFER			1			
			94220-MB7-710	SCHILD, SCHEINWERFER				1		
0,1	11	64221-MA2-000	GUMMI, SCHEINWERFERSCHILD			1	1			
	12	64222-MA2-000	PLATTE, SCHEINWERFERGUMMI UEBEN			2	2			

2-E8

F-31

Fairing
(CB900F2a - F2c)

Profilege
(CB900F2a - F2c)

Verkleidung
(CB900F2a - F2c)

Carena
(CB900F2a - F2c)

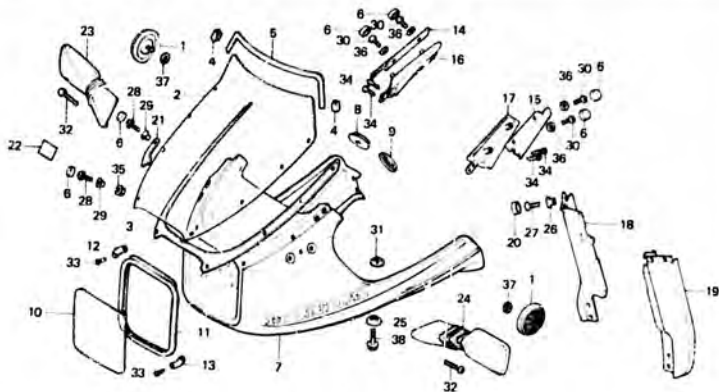

B43b-46/8

Wartungspunkt	AP	Ref. Nr.	Teile-Nr.	Beschreibung	Menge				Serien-Nr.	Gebiets-Code
					Fz	Fa	Fa 12a	Fc F2c		
		13	64223-MA2-000	PLATTE, SCHEINWERFERGUMMI				2	2	
				UNTEN						
		14	64236-438-850ZA	PFOSTEN, R. *R-110*				1	1	
			64236-438-850ZB	PFOSTEN, R. *NH-110M-U*				1	1	
		15	64237-438-850ZA	PFOSTEN, L. *R-110*				1	1	
			64237-438-850ZB	PFOSTEN, L. *NH-110M-U*				1	1	
		16	64236-MA2-500	POLSTER, R., PFOSTEN				1	1	
		17	64233-MA2-300	POLSTER, L., PFOSTEN				1	1	
		18	64260-438-850ZA	BEINSCHILD, R. *R-110*				1	1	
			64260-438-850ZB	BEINSCHILD, R. *NH-110M-U*				1		
			64260-MB7-710ZC	BEINSCHILD, R. *R-110*					1	
			64260-MB7-710ZD	BEINSCHILD, R. *NH-110M-U*					1	
		19	64270-438-850ZA	BEINSCHILD, L. *R-110*				1		

2-E9

F-31

Fairing
(CB900F2a - F2c)

Profilage
(CB900F2a - F2c)

Verkleidung
(CB900F2a - F2c)

Carena
(CB900F2a - F2c)

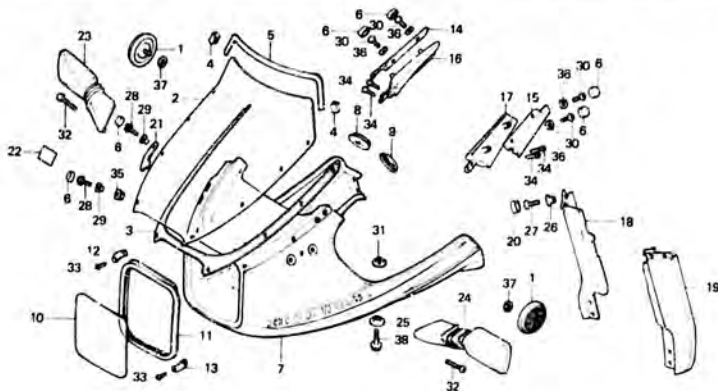

B3.18 2/81

Wartungspunkt	AP	Ref. Nr.	Teile-Nr.	Beschreibung	Menge				Serien-Nr.	Gebiets-Code
					F2	Fa	Fb	Fc		
		64270-438-850ZB	BEINSCHILD, L. *NH-110M-U*					1		
		64270-MB7-710ZC	BEINSCHILD, L. *R-110*						1	
		64270-MB7-710ZD	BEINSCHILD, L. *NH-110M-U*						1	
	20	64279-MA2-000	KAPPE, BEINSCHILDSCHRAUBE					4	4	
	21	64513-MA2-000	FESTSTELLPLATTE, SCHEIBE					2	2	
	22	87522-463-930	VORSICHTSZETTEL, WINDSCHUTZ-SCHEIBE					1	1	DK, DM, E, ED, SA, U
		87522-463-940	VORSICHTSZETTEL, WINDSCHUTZ-SCHEIBE					1	1	G
		87522-463-950	VORSICHTSZETTEL, WINDSCHUTZ-SCHEIBE					1	1	F
	23	88110-MA2-620	RUECKSPIEGEL, R.					1	1	DK, DM, E, ED, F, G, SA
		88110-MA2-650	RUECKSPIEGEL, R.					1	1	U
	24	88120-MA2-620	RUECKSPIEGEL, L.					1	1	DK, DM, E, ED, F, G, SA
		88120-MA2-650	RUECKSPIEGEL, L.					1	1	U

2-E10

F-31

Fairing
(CB900F2a - F2c)

Profilege
(CB900F2a - F2c)

Verkleidung
(CB900F2a - F2c)

Carena
(CB900F2a - F2c)

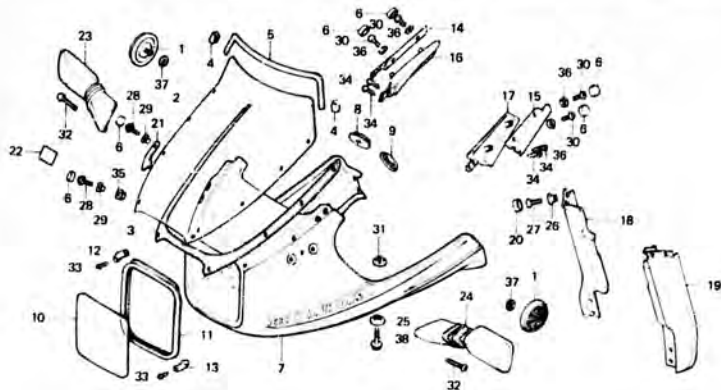

8435-405

Wartungspunkt	AP	Ref. Nr.	Teile-Nr.	Beschreibung	Menge				Serien-Nr.	Gebiets-Code
					Fz	Fa	Fz	Fc		
		25	90002-438-850	HOELSE B			2	2		
		26	90003-438-850	HUELSE C			4	4		
		27	90005-MA2-000	FESTSTELLSCHRAUBE, BEINSCHILD			4	4		
		28	90006-MA2-000	FESTSTELLSCHRAUBE, SCHEIBE			4	4		
		29	90007-438-850	HUELSE, 6X8,6			4	4		
		30	90709-MA2-000	FESTSTELLSCHRAUBE P, SCHEIBE			4	4		
		31	90400-438-850	SCHEIBE, 6X22			2	2		
		32	93500-0602P	KEGELKOPFSCHRAUBE, 6X28			4	4		
		33	93901-1236L	SCHNEIDSCHRAUBE, 3X12			8	8		
		34	93903-14310	SCHNEIDSCHRAUBE, 4X12			4	4		
		35	94050-04000	FLANSCHENMUTTER, 4MM			2	2		
		36	90502-438-850	FESTSTELLSCHRAUBE, WINDSCHEIBE			4	4		

2-E11**F-31**

Fairing
(CB900F2a - F2c)

Profilege
(CB900F2a - F2c)

Verkleidung
(CB900F2a - F2c)

Carena
(CB900F2a - F2c)

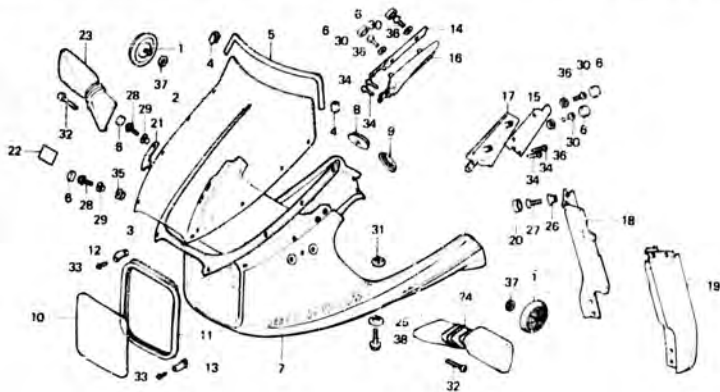

04 11-81

Wartungspunkt	AP	Ref. Nr.	Teile-Nr.	Beschreibung	Menge					Serien-Nr.	Gebiets-Code
					Fz	Fa	Fb	F2a	Fc		
		37	94111-04000	FEDERRING, 6MM			2		2		
		33	96000-06028-02	FLANSCHENSCHRAUBE, 6X28			6		6		

2-E12

F-32

Fairing stay
(CB900F2s • F2c)

Appui de profilage
(CB900F2s • F2c)

Verkleidungsstütze
(CB900F2s • F2c)

Carena tirante
(CB900F2s • F2c)

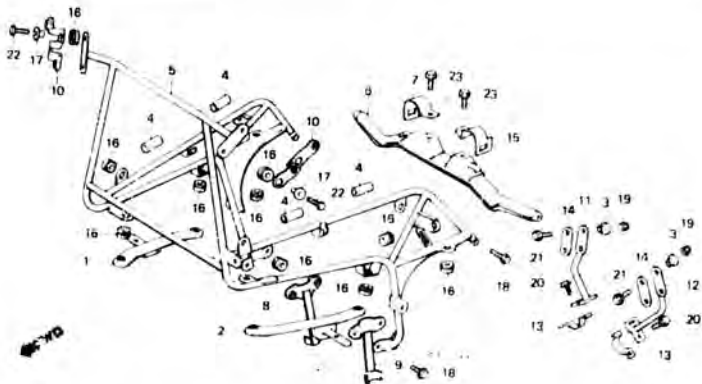

Wartungspunkt	AP	Ref. Nr.	Teile-Nr.	Beschreibung	Menge				Serien-Nr	Gebiets-Code
					CB900F	F2c	F2s	F2c		
STUETZE, R. V. BLINKER	0,1	1	33A71-438-850	STUETZE, R. V. BLINKER		1	1			
STUETZE, L. V. BLINKER		2	33A72-438-850	STUETZE, L. V. BLINKER		1	1			
HAUPTSTUETZE, VERKLEIDUNG	0,6	3	61104-347-850	HUELSE, V. FENDER		4	4			
STUETZE, VERKLEIDUNG	0,2	4	64247-438-850	BEFESTIGUNGSKISSEN, TASCH		10	10			
		5	64501-438-850ZA	HAUPTSTUETZE, VERKLEIDUNG		1				
				R-110						
			64501-438-850ZB	HAUPTSTUETZE, VERKLEIDUNG		1				
				NH-1						
			64501-4B7-710ZA	HAUPTSTUETZE, VERKLEIDUNG			1			
				R-110						
			64501-4B7-710ZB	HAUPTSTUETZE, VERKLEIDUNG			1			
				NH-1						
		6	64502-438-850ZA	STUETZE, VERKLEIDUNG		1	1			
			64502-438-850ZB	STUETZE, VERKLEIDUNG		1	1			
		7	64503-438-850	BAND, R. H. STUETZE		1	1			

2-E13

F-32

Fairing stay
(CB900F2a - F2c)

Appui de profilage
(CB900F2a - F2c)

Vrekleidungsstütze
(CB900F2a - F2c)

Carena tirante
(CB900F2a - F2c)

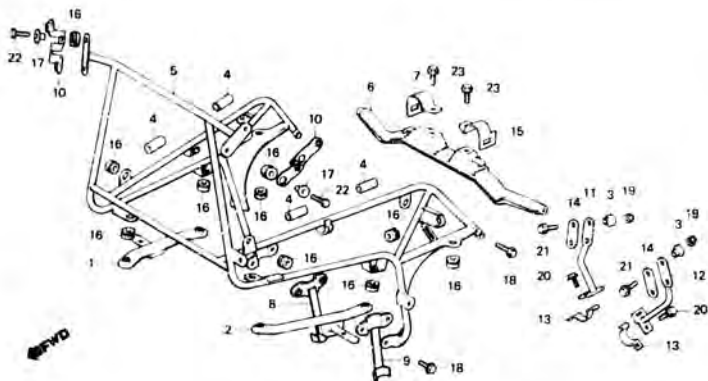

8479 4/82

Wartungspunkt	AP	Ref. Nr.	Teile-Nr.	Beschreibung	Menge				Serien-Nr	Gebiets-Code
					Fz	Fa	Fa	Fc F2c		
		8	64504-438-8502A	BAND, R. HAUPTSTUETZE *R-110*				1		
			64504-438-8502B	BAND, R. HAUPTSTUETZE *NH-1*				1		
			64304-MB7-7102A	BAND, R. HAUPTSTUETZE *R-110*					1	
			64904-MB7-7102B	BAND, R. HAUPTSTUETZE *NH-1*					1	
		3	64505-438-8502A	BAND, L. HAUPTSTUETZE *R-110*				1		
			64505-438-8502B	BAND, L. HAUPTSTUETZE *NH-1*				1		
			64505-MB7-7102A	BAND, L. HAUPTSTUETZE *R-110*					1	
			64505-MB7-7102B	BAND, L. HAUPTSTUETZE *NH-1*					1	
		10	64506-438-850	HAUPTSTUETZE, OF *N				2	2	
		11	64509-438-8502A	STUETZE, R. REINSCHILD *R-110*				1	1	

2-E14

F-32

Fairing stay
(CB900F2a - F2c)

Appui de profilage
(CB900F2a - F2c)

Vrekleidungsstütze
(CB900F2a - F2c)

Carena tirante
(CB900F2a - F2c)

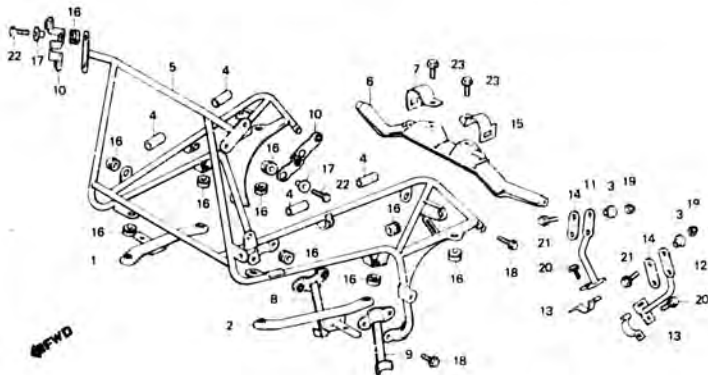

9475 - 4/4

Wartungspunkt	AP	Ref. Nr.	Teile-Nr.	Beschreibung	Menge				Serien Nr	Gebiets-Code
					CB900	Fz	FA	Fu F2a Fc 12c		
		12	64509-438-850Z3	STUETZE, R. BEINSCHILD *NH-1*	1	1				
			64510-438-850ZA	STUETZE, L. BEINSCHILD *R-110*	1	1				
			64510-438-850ZB	STUETZE, L. BEINSCHILD *NH-1*	1	1				
		13	64511-438-850ZA	BAND, BEINSCHILD *R-110*	2					
			64511-438-850ZB	BAND, BEINSCHILD *NH-1*	2					
			64511-MB7-710ZA	BAND, BEINSCHILD *R-110*		2				
			64511-MB7-710ZB	BAND, BEINSCHILD *NH-1*		2				
		14	64512-438-850	GUMMI, BEINSCHILD	2	2				
		15	64513-436-850	BAND, L. H. STUETZE	1	1				
		16	84703-460-000	GUMMI, SCHLUSSLICHTKISSEN	10	10				
		17	90001-438-850	MUELSE A	18	18				

2-E 15**F-32**

Fairing stay
(CB900F2a - F2c)

Appui de profilage
(CB900F2a - F2c)

Vrekleidungsstütze
(CB900F2a - F2c)

Carena tirante
(CB900F2a - F2c)

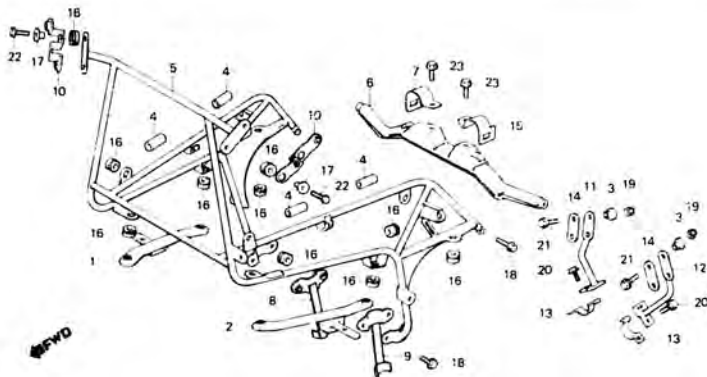

31/11 1/1

Wartungspunkt	AP	Ref. Nr.	Teile-Nr.	Beschreibung	Menge				Serien Nr.	Gebiets-Code
					Fz	FA	FB	Fz/Fc		
		18	90100-438-850	SPEZIALFLANSCHSCHRAUBE, 8x22				6	6	
		19	94021-06020-05	HUTMUTTER, 6MM				4	4	
		20	95700-06016-00	FLANSCHENSCHRAUBE, 6x16				2	2	
		21	95700-06020-00	FLANSCHENSCHRAUBE, 6x20				4	4	
		22	95700-06022-00	FLANSCHENSCHRAUBE, 6x22				4	4	
		23	95700-06025-00	FLANSCHENSCHRAUBE, 6x25				2	2	

2-E16

F-33

Fairing pocket
(CB900F2b • F2c)

Poche de profilage
(CB900F2b • F2c)

Verkleidungstasche
(CB900F2b • F2c)

Bolsillo de carena
(CB900F2b • F2c)

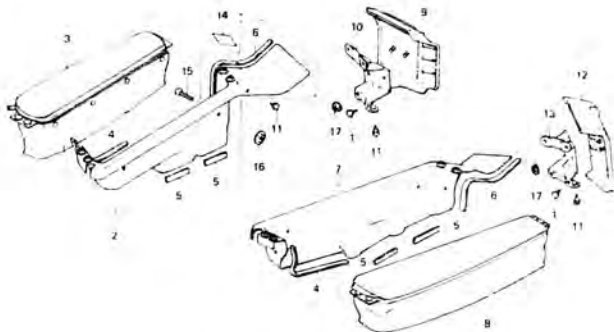

07-9-88

Wartungspunkt	AP	Ref. Nr.	Teile-Nr.	Beschreibung	Menge				Serien-Nr.	Gebiets Code
					Fz	Fa	Fz/Fa	Fz/Fa		
TASCHE KOMPL.	0.3	1	40514-333-000	STUEPSEL, KETTENGEGÄHUSE			4	4		
STUETZE, R. KNIEPOLSTER	0.1	2	64240-438-850	TASCHE KOMPL., R.			1	1		
EINSCHL. DAZUGEHÖRIGER TEIL		3	64240-MB7-710	TASCHE KOMPL., R.			1	1		
		4	64245-438-850	SEITENTASCHE, R.			1	1		
		5	64248-438-850	DICHTGUMMI B, TASCHE			2	2		
		6	64249-438-850	DICHTGUMMI A, TASCHE			2	2		
		7	64250-438-850	TASCHE KOMPL., L.			1	1		
		8	64250-MB7-710	TASCHE KOMPL., L.			1	1		
		9	64255-438-850	SEITENTASCHE, L.			1	1		
		9	64261-438-850	POLSTER, R. KNEE			1	1		
		10	64262-438-850	STUETZE, R. KNIEPOLSTER			1	1		

2-F1

F-33

Fairing pocket
(CB900F2a • F2c)

Poche de profilage
(CB900F2a • F2c)

Verkleidungstasche
(CB900F2a • F2c)

Bolsillo de carena
(CB900F2a • F2c)

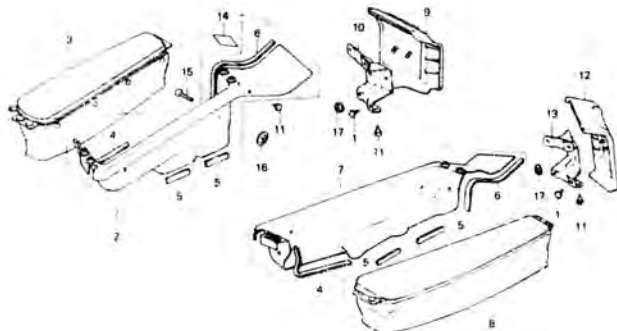

B43E-4R

Wartungspunkt	AP	Ref. Nr.	Teile-Nr.	Beschreibung	Menge				Serien-Nr.	Gebiets-Code
					F3	F4	F5	F2c		
		11	64264-43B-850	FESTSTELLGUMMITZELLE, BREMSKLOTZ			4	4		
		12	64271-43B-850	POLSTER, L. KNIE			1	1		
		13	64272-43B-850	STÜTZE, L. KNIEPOLSTER			1	1		
		14	87523-43B-840	VORSICHTSZEITEL, TASCHE			1	1		DK, DM, E, ED, SA, J, G
			87513-43B-850	VORSICHTSZEITEL, TASCHE			1	1		F
			87522-43B-930	VORSICHTSZEITEL, TASCHE			1	1		DK, DM, E, ED, SA, J, G
			87523-MB7-700	VORSICHTSZEITEL, TASCHE				1		G
			87523-MB7-710	VORSICHTSZEITEL, TASCHE				1		G
			87523-MB7-730	VORSICHTSZEITEL, TASCHE				1		F
		15	90008-43B-850	ANKERSCHRAUBE, 6X28			8	8		

2-F2**F-33**

Fairing pocket
(CB900F2b - F2c)

Focière de profilage
(CB900F2b - F2c)

Verkleidungstasche
(CB900F2b - F2c)

Boisillo de carena
(CB900F2b - F2c)

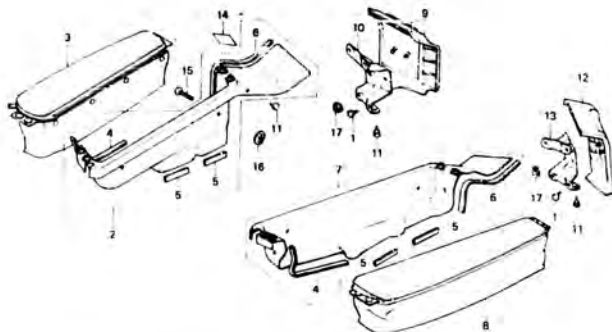

B436-48

Wartungspunkt	AF	Ref. Nr.	Teile-Nr.	Beschreibung	Mengen				Serien-Nr.	Gebiets-Code
					F2	Fa	Fb F2c	Fc F2c		
		16	90400-438-850	SCHEIBE, 6X22			8	8		
		17	94050-06000	FLANSCHENMUTTER, 6MM			4	4		

2-F3

F-34

Fueltank stripe

Raie de réservoir d'essence

Benzintank-Streifen

Franja de tanque de combustible

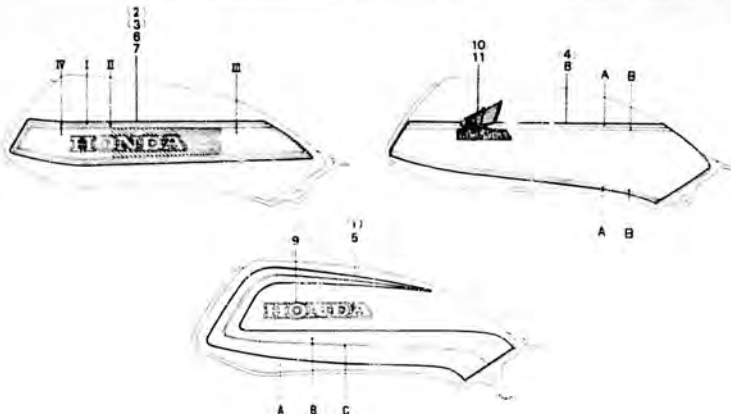

8438-11

Wartungspunkt	AP	Ref. Nr.	Teile-Nr.	Beschreibung	Menge				Serien-Nr.	Gebiets-Code
					C8900	Fz	Fa	Fc		
		1	87121-MB7-610ZA	STREIFEN, R. BENZINTANK (A,M) *TYPE-1*						1
			87121-MB7-610ZB	STREIFEN, R. BENZINTANK (A,M) *TYPE-2*						1
			87121-MB7-610ZC	STREIFEN, R. BENZINTANK (A,M) *TYPE-3*						1
			87121-MB7-610ZD	STREIFEN, R. BENZINTANK (A,M) *TYPE-4*						1
		2	87121-438-300ZA	STREIFEN, BENZINTANK R. (T.M.) *A-07*						1
			87121-438-710ZA	STREIFEN, BENZINTANK R. (T.M.) *NH-104M-U*						1
			87121-438-710ZB	STREIFEN, BENZINTANK R. (T.M.) *R-107C-U*						1
			87121-438-710ZC	STREIFEN, BENZINTANK R. (T.M.) *PB-107C-U*						1
			87121-438-710ZD	STREIFEN, BENZINTANK R. (T.M.) *Ni-1*						1
		3	87121-438-730ZA	STREIFEN, BENZINTANK R. (T.M.) *TYPE A*						1

Farbentabelle für Benzintankstreifen (CB900F)

Typ des Streifen	Benzintankstreifen-Flugfarbe	Stellung		
		A	B	C
TYF-1	Perlmuschelweiß	Rot	Silber-III	Schwarz
TYF-2	Schwarz	Rot	Silber-II	Gold
TYF-3	Candy-Lurgunderrot-U	Orange	Schwarz	Gold
TYF-4	Candy-Schwarzblau-Mer-U	Hellblau-metallic	Dunkelblau	Gold

1981.11.10

E

2-F3

2-F4

F-34

Fuehtank stripe

Rais de réservoir d'essence

Benzintank-Streifen

Franja de tanque de combustible

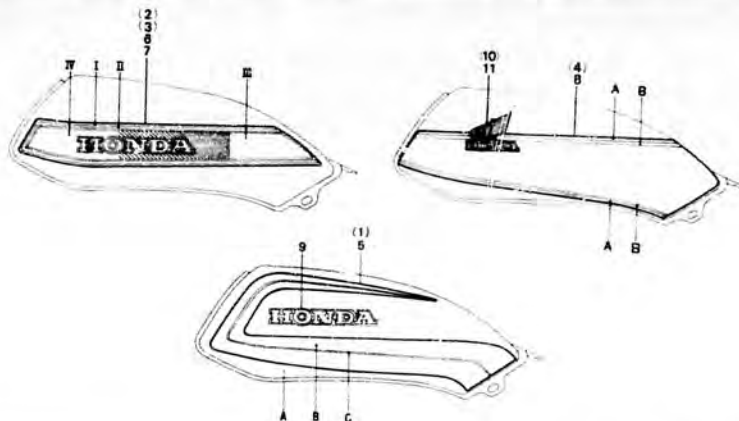

8436-114

Wartungspunkt	AP	Ref. Nr.	Teile-Nr.	Beschreibung	Menge				Serien-Nr.	Gabiets-Code
					Fz	Fa	Fz Fa	Fz Fa Fz C		
			87121-438-7302B	STREIFEN, BENZINTANK R. (T.M.) *TYPE 5*	1					
			87121-438-7302C	STREIFEN, BENZINTANK R. (T.M.) *TYPE C*	1					
			87121-438-7302D	STREIFEN, BENZINTANK R. (T.M.) *TYPE D*	1					
	4		87121-MB7-7102A	STREIFEN, R. BENZINTANK (A.M) *TYPE-1*						
			87121-MB7-7102B	STREIFEN, R. BENZINTANK (A.M) *TYPE-2*						
			87121-438-8502A	STREIFEN, R. BENZINTANK (A.M) *TYPE 1*	1					
			87121-438-8502B	STREIFEN, BENZINTANK R. (T.M.) *TYPE 2*	1					
	5		87122-MB7-6102A	STREIFEN, L. BENZINTANK (A.M) *TYPE-1*	1					
			87122-MB7-6102B	STREIFEN, L. BENZINTANK (A.M) *TYPE-2*	1					
			87122-MB7-6102C	STREIFEN, L. BENZINTANK (A.M) *TYPE-3*	1					

Farbentabelle für Benzintankstreifen (CB900Fa)

Typ des Streifen	Bezeichnung			
	Benzintank-Magnum	I	II	III
TYPE A	Magnum silbermetallisch-U	Grünfarben	Orange	Schwarz
TYPE B	Cardy hochglanzschwarz-U	Grünfarben	Blau	Orange
TYPE C	Cardy hochglanzschwarz-U	Goldfarben	Schwarz	Schwarz
TYPE D	Schwarz	Hellblau	Schwarz	Schwarz

2-F5

F-34

Fueltank stripe

Rais de réservoir d'essence

Benzintank-Streifen

Franja de tanque de combustible

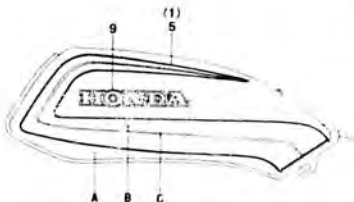
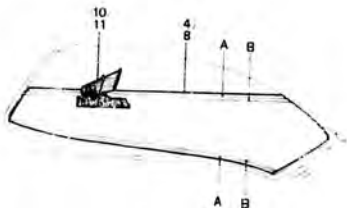
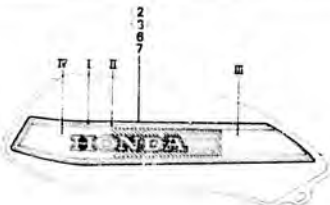

943P-114

Wartungspunkt	AP	Ref. Nr.	Teile-Nr.	Beschreibung	Messung CBBGO Fz Fa Es Fz B Zc FZc	Serien-Nr.	Gebiets-Code
			87122-MB7-610ZD	STREIFEN, L. BENZINTANK (A,M) *TYPE-A*	1		
	6	87122-438-3002A	STREIFEN, BENZINTANK L. (T.M.) *A-07*	1			
		87122-438-7102A	STREIFEN, BENZINTANK L. (T.M.) *HM-104M-U*	1			
		87122-438-7102B	STREIFEN, BENZINTANK L. (T.M.) *R-107C-U*	1			
		87122-438-7102C	STREIFEN, BENZINTANK L. (T.M.) *PB-107C-U*	1			
		87122-438-7102D	STREIFEN, BENZINTANK L. (T.M.) *NH-1*	1			
	7	87122-438-7302A	STREIFEN, BENZINTANK L. (T.M.) *TYPE A*	1			
		87122-438-7302B	STREIFEN, BENZINTANK L. (T.M.) *TYPE B*	1			
		87122-438-7302C	STREIFEN, BENZINTANK L. (T.M.) *TYPE C*	1			
		87122-438-7302D	STREIFEN, BENZINTANK L. (T.M.) *TYPE D*	1			

1981.11.10

E

2-F5

2-F6

F-34

Fuel tank stripe

Rale de réservoir d'essence

Benzintank-Streifen

Franja de tanques de combustible

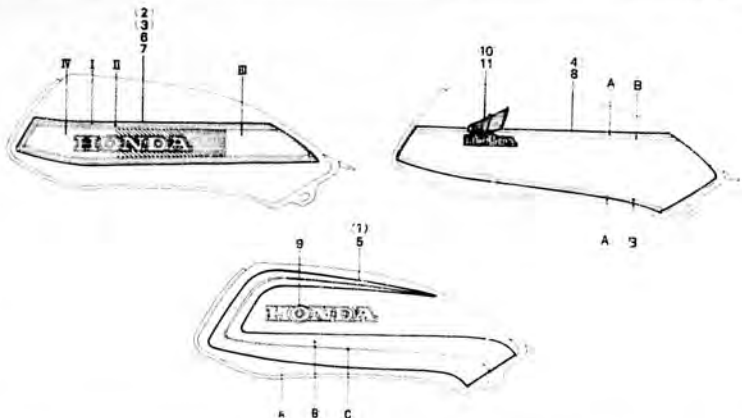

B:38-114

Wartungspunkt	AP	Ref. Nr.	Teile-Nr.	Beschreibung	Menge				Serien-Nr.	Gebiets-Code
					Fz	FA	1a	F2a		
		8	87122-MB7-710ZA	STREIFEN, L. BENZINTANK (A,M)					1	
				TYPE-1						
		87122-MB7-710ZB	STREIFEN, L. BENZINTANK (A,M)					1		
				TYPE-2						
		87122-438-850ZA	STREIFEN, BENZINTANK L.					1		
			(T.M.)	*TYPE 1*						
		87122-438-850ZB	STREIFEN, BENZINTANK L.					1		
			(T.M.)	*TYPE 2*						
		9	87123-MB7-610	MARKE, BENZINTANK					2	
		10	87122-KB7-670	MARKE, R. BENZINTANK					1	
			87123-395-670	MARKE, R. BENZINTANK					1	
		11	87123-KB7-670	MARKE, L. BENZINTANK					1	
			87124-395-670	MARKE, L. BENZINTANK					1	

Farbentabells für Benzintankstreifen (CB900F2a - F2c)

Teil des Streifen	Bezeichnung		A	B
	Benzintankstreifen			
TYP 1	Monzarol	Co. zinweiß	Monzarol	
TYP 2	Magnesiumbermetalic	Cottinweiß	Blaü	

2-F7

F-35

**Fairing stripe
(CB900F2a - F2c)**

**Marque de profilage
(CB900F2a - F2c)**

**Marque Verkleidung
(CB900F2a - F2c)**

**Mavca carena
(CB900F2a - F2c)**

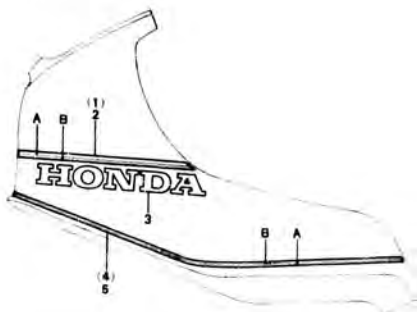

B438-50

Wartungspunkt	AP	Ref. Nr.	Teile-Nr.	Beschreibung	Menge CB900				Serien-Nr.	Gebiets-Code
					F2	FA	Fa	F2a Fc F2c		
		1	87115-438-850ZA	STREIFEN A, R. VERKLEIDUNG (A.M.) *TYPE 1*			1	1		
			87115-438-850ZB	STREIFEN A, R. VERKLEIDUNG (A.M.) *TYPE 2*			1	1		
		2	87116-438-850ZA	STREIFEN A, L. VERKLEIDUNG (A.M.) *TYPE 1*			1	1		
			87116-438-850ZB	STREIFEN A, L. VERKLEIDUNG (A.M.) *TYPE 2*			1	1		
		3	87117-438-850	MARKE. HONDA			2	2		
		4	87116-438-850ZA	STREIFEN B, R. VERKLEIDUNG (A.M.) *TYPE 1*			1	1		
			87118-438-850ZB	STREIFEN B, R. VERKLEIDUNG (A.M.) *TYPE 2*			1	1		
		5	87119-438-850ZA	STREIFEN B, L. VERKLEIDUNG (A.M.) *TYPE 1*			1	1		
			87119-438-850ZB	STREIFEN B, L. VERKLEIDUNG (A.M.) *TYPE 2*			1	1		

Farbentabelle für Verkleidungsstreifen (CB900F2a - F2c)

Typ des Streifen		Stellung	
		A	B
TYP 1	Monzarot	Cartonweiß	Monzarot
TYP 2	Magnesiumfaser metallic	Cartonweiß	Blau

2-F8

F-36

Side cover mark
(CB900F2a • Fc • F2c)

Marque de couvercle lateral
(CB900F2b • Fc • F2c)

Marque Seitendeckel
(CB900F2b • Fc • F2c)

Marca cubierta lateral
(CB900F2b • Fc • F2c)

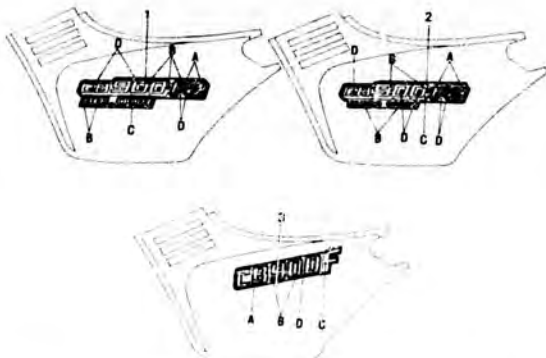

B428 - 115

Wartungspunkt	AP	Ref. Nr.	Teile-Nr.	Beschreibung	Menge				Serien-Nr.	Gebiets-Code
					Fz	Fa	Fa 12a	Fc F2c		
		1	87123-438-8102A	MARKE, R. SEITENDECKEL (A.M.) *TYPE 1*	2	2			E	
			87123-438-8402B	MARKE, R. SEITENDECKEL (A.M.) *TYPE 2*	2	2			E	
		2	87123-438-8502A	MARKE, R. SEITENDECKEL (A.M.) *TYPE 1*	2	2			DK, DM, ED, F, G, SA, J	
			87123-438-8502B	MARKE, P. SEITENDECKEL (A.M.) *TYPE 2*	2	2			DK, DM, ED, F, G, SA, J	
		3	87124-MB7-6102A	MARKE, SEITENDECKEL (A.M.) *TYPE-1*		2				
			87124-MB7-6102B	MARKE, SEITENDECKEL (A.M.) *TYPE-2*		2				
			87124-MB7-6102C	MARKE, SEITENDECKEL (A.M.) *TYPE-3*		2				
			87124-MB7-6102D	MARKE, SEITENDECKEL (A.M.) *TYPE-4*		2				

Véase el bloque F-39 para la tabla de color de franja de marca de cubierta lateral.

2-F9

F-37

Side cover stripe
(CB900Fc • F2c)

Rayure de couvercle latéral
(CB900Fc • F2c)

Seitendeckel Streifen
(CB900Fc • F2c)

Franja de cubierta lateral
(CB900Fc • F2c)

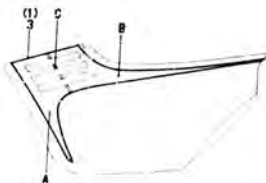

R438 - 116

Wartungspunkt	AP	Ref. Nr.	Teil-Nr.	Beschreibung	Menge				Serien-Nr.	Gebiets-Code
					F2	Fa	Fb	Fc F2c		
		1	87128-MB7-610ZA	STREIFEN, R. SEITENDECKEL (A,M) *TYPE-1*	1					
		1	87128-MB7-610ZB	STREIFEN, R. SEITENDECKEL (A,M) *TYPE-2*	1					
		1	87128-MB7-610ZC	STREIFEN, R. SEITENDECKEL (A,M) *TYPE-3*	1					
		1	87128-MB7-610ZD	STREIFEN, R. SEITENDECKEL (A,M) *TYPE-4*	1					
		2	87128-438-850ZA	STREIFEN, R. SEITENDECKEL (A,M) *TYPE-1*	1					
		1	87128-438-850ZB	STREIFEN, R. SEITENDECKEL (A,M) *TYPE-2*	1					
		3	87129-MB7-610ZA	STREIFEN, L. SEITENDECKEL (A,M) *TYPE-1*	1					
		1	87129-MB7-610ZB	STREIFEN, L. SEITENDECKEL (A,M) *TYPE-2*	1					
		1	87129-MB7-610ZC	STREIFEN, L. SEITENDECKEL (A,M) *TYPE-3*	1					
		1	87129-MB7-610ZD	STREIFEN, L. SEITENDECKEL (A,M) *TYPE-4*	1					

Farbentabelle für Seitendeckelstreifen (CB900Fc)

Typ des streifen	Bemerkung Hauptfarbe	Strahlung		
		A	B	C
TYF-1	Perlmutter weiß	Rot	Silber-B	Schwarz
TYF-2	Schwarz	Rot	Silber-B	Gold
TYF-3	Candy burgunderrot-U	Orange	Schwarz	Gold
TYF-4	Candy santonblau-U	Hellblau-metallic	Dunkelblau	Gold

2-F10

F-37

**Side cover stripe
(CB900Fc • F2c)**

**Rayure de couvercle latéral
(CB900Fc • F2c)**

**Seitendeckel Streifen
(CB900Fc • F2c)**

**Franja de cubierta lateral
(CB900Fc • F2c)**



5432-11c

Wartungspunkt	AP	Ref. Nr.	Teile-Nr.	Beschreibung	Menge				Serien-Nr.	Gebiets-Code
					Fz	Fa	Fb	Fc		
		A	87129-438-850ZA	STREIFEN, L. SEITENDECKEL (A,M) *TYPE-1*					1	
			87129-438-850ZB	STREIFEN, L. SEITENDECKEL (A,M) *TYPE-2*					1	

Farbentabelle für Seitendeckelstreifen (CB900F2c)

Teil des Streifen	Benennung Hauptfarbe	Bezeichnung	
		A	B
TYP 1	Montzrot	Cottinweiß	Montzrot
TYP 2	Magnesiumbermetallisch	Cottinweiß	Blau

2-F11

F-38

**Rear cowl stripe
(CB900Fc • F2c)**

**Rayure d'avant arrière
(CB900Fc • F2c)**

**Hinterer vordelungstreifen
(CB900Fc • F2c)**

**Franja de cubra tablero trasero
(CB900Fc • F2c)**

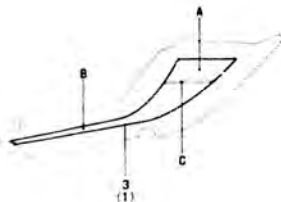

8438-117

Wartungspunkt	AP	Ref. Nr.	Teile-Nr.	Beschreibung	Menge				Serien-Nr.	Gebiets-Code
					CB900	Fc	Fa	Fb F2a Fc F2c		
		1	87125-MB7-610ZA	STREIFEN, R. H. HAUBEN- VERKLEIDUNG (A,M) *TYPE-1*				1		
			87125-MB7-610ZB	STREIFEN, R. H. HAUBEN- VERKLEIDUNG (A,M) *TYPE-2*				1		
			87125-MB7-610ZC	STREIFEN, R. H. HAUBEN- VERKLEIDUNG (A,M) *TYPE-3*				1		
			87125-MB7-610ZD	STREIFEN, R. H. HAUBEN- VERKLEIDUNG (A,M) *TYPE-4*				1		
		2	87125-438-850ZA	STREIFEN, R. H. HAUBEN- VERKLEIDUNG (A,M) *TYPE-1*				1		
			87125-438-850ZB	STREIFEN, R. H. HAUBEN- VERKLEIDUNG (A,M) *TYPE-2*				1		
		3	87126-M17-610ZA	STREIFEN, L. H. HAUBEN- VERKLEIDUNG (A,M) *TYPE-1*				1		
			87126-M17-610ZB	STREIFEN, L. H. HAUBEN- VERKLEIDUNG (A,M) *TYPE-2*				1		
			87126-M17-610ZC	STREIFEN, L. H. HAUBEN- VERKLEIDUNG (A,M) *TYPE-3*				1		
			87126-MB7-610ZD	STREIFEN, L. H. HAUBEN- VERKLEIDUNG (A,M) *TYPE-4*				1		

**Farbentabelle für hinterer
Verkleidungstreifen (CB900Fc)**

Typ des streifen	Bezeichnung Hauptfarbe	Stellung		
		A	B	C
TYP-1	Perlmutter- weiß	Rot	Silber-18	Schwarz
TYP-2	Schwarz	Rot	Silber-18	Gold
TYP-3	Candy- Burgunder- rot-U	Orange	Schwarz	Gold
TYP-4	Candy- Vergewittert- blau-U	Metall- blau	Dunkelblau	Gold

2-F12**F-38**

Rear cowl strip
(CB900Fc • F2c)

Rayure d'avant arrière
(CB900Fc • F2c)

Hinterer Verkleidungsstreifen
(CB900Fc • F2c)

Franja de cubra tablero trasero
(CB900Fc • F2c)

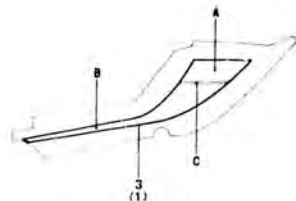

028-117

Wartungspunkt	AP	Ref. Nr.	Teile-Nr.	Beschreibung	Menge				Serien-Nr.	Gebiets-Code
					Fz	Fa	Fa F2a	Fc F2c		
		4	87126-438-8502A	STREIFEN, L. H. HAUBEN- VERKLEIDUNG (A,M) *TYPE-1*				1		
			87126-438-8502B	STREIFEN, L. H. HAUBEN- VERKLEIDUNG (A,M) *TYPE-2*				1		

Farbentabelle für hinteren Verkleidungsstreifen (CB900F2c)

Typ der Verkleidung	Benzolans- Hauptfarbe	Stellung	
		A	B
TYP 1	Monzarot	Grün-schwarz	Monzarot
TYP 2	Magnesiumüber- metallisch	Grün-schwarz	Blau

2-F 13

F-39

Color chart

(Side cover mark-CB900F2a • Fc • F2c)

Table de couleur

(Marque de couvercle lateral-CB900F2a • Fc • F2c)

Farbentabelle

(Marque seitendeckel-CB900F2a • Fc •F2c)

Tabla de color

(Marca cubierta lateral-CB900F2a • Fc • F2c)

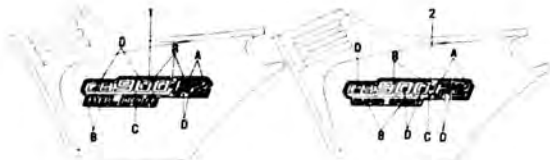

B439-115

Farbentabelle für Seitendeckelmarke (CB900Fc)

Bestandteile Typ des gestrichen	Stellung			
	A	B	C	D
TYP.1 Part. metallic weiß	Schwarz	Gold	Rot	Dunkel schwarz
TYP.2 Candy Orange dunkel u.	Schwarz	Gold	Rot	Schwarz
TYP.3 Candy orange dunkel u.	Schwarz	Gold	Orange	Candy orange dunkel u.
TYP.4 Candy orange dunkel u.	Schwarz	Gold	Rot	Candy orange dunkel u.

**Farbentabelle für seitendeckel Marke
(CB900F2a • F2c - E)**

Bestandteile Typ des gestrichen	Stellung			
	A	B	C	D
TYP.1 Magnesium silber metallisch	Rot	Weiß	Schwarz	Magnesium
TYP.2 Magnesium silber metallisch	Rot	Weiß	Schwarz	Magnesium silber metallisch

**Farbentabelle für seitendeckel Marke
(CB900F2a • F2c - G, F, ED, DK, DM, SA, U)**

Bestandteile Typ des gestrichen	Stellung			
	A	B	C	D
TYP.1 Magnesium silber metallisch	Rot	Weiß	Schwarz	Magnesium
TYP.2 Magnesium silber metallisch	Rot	Weiß	Schwarz	Magnesium silber metallisch

2-N1

	98069-58726	C6
	98069-58727	C6
	98069-59717	C7
	98069-59726	C7
	98069-59727	C7
Par No	Address No	2-D9
N de piece	N de Adresse	11
	98200-53000	*6

Jolo No	Address No	99007
No de doc.	Niz de circuit	

95700-08032-00	M15	99001-08120	2-E5
		99001-10170	2-E6
95700-08040-00	M3	99001-14270	2-E6
95700-08040-00	M5	99001-19900	2-E6
95700-08065-00	E3	99003-10000	2-E6
95700-08065-00	E3	99003-30000	2-E6
95723-10065-00	E3	99003-90000	2-E6
95725-06029-00	DV	99006-12000	2-E6
	F3	99006-22000	2-E6
95800-08055-07	J10	99006-24000	2-E6
95903-10040-00	J7	99101-393-0680	F10
95911-08100-00	J12	99102-393-0980	F10
	J14	99103-MA1-1420	F10
		99103-MA1-0420	F10

96000

96000-06010-00	D11
96000-06014-00	D8
96000-06018-01	D10
96000-06025-00	G2
	2-D15
	2-E4
96000-06027-02	2-E11
96000-06032-00	D3
	F3
96000-06035-00	C2
	D14
	2-D15
	2-E4
96000-06040-00	D3
	D8
	D14
96000-0 55-00	D13
96000-06069-00	D14
96000-06070-00	L1
	D14
96100-00030	D6
96110-02040	E11
96140-03020-10	J12
	J15
96140-03040-10	K13
96140-03050-10	K13
	K16
	L3
96150-03040-10	K13
	K16
	L3
96201-00000	2-L1
	2-C4
96211-08000	M13
96220-00113	F3

98000

98069-58716	C6
98069-58717	C6
98069-58717	C6