

C 1

BLOCKINDEX - MOTORGRUPPE



E 1 Ölwanne	C 7	E 7 Luftmaschine, Dynamolücke	D 1	E 15 Kurbelwelle, Endbolz	E 4
E 2 Zylinderkopfdeckel	C 3	E 8 Kupplungsstockel	D 7	E 16 Primärwelle	E 8
E 3 Zylinderkopf	C 2	E 9 Kupplung	D 6	E 17 Getriebe	E 12
E 4 Nockenwelle, Ventile	C 1	E 10 Linker Deckel, Zündventiltrieb	D 7	E 18 Gangschaltwalze	E 16
E 5 Steuerkette, Spanner	C 2	E 11 Anlassermotor	D 9	E 19 Vergaser/Kompl. Gestänge	E 2
E 8 Zylinder	C 16	F 12 Linker Kurbelgehäusestecker, Ölwanne	D 12	E 19-1 Vergaser (Einzelteil)	F 8
		E 13 Ölfilter, Ölwanne	D 15	E 20 Autom. atisches Benzinohr	F 11
		E 14 Kurbelgehäuse	E 1	EOP 1 Dichtung Satz A	F 12
				EOP 2 Dichtung Satz B	F 14

E 4

E-15

Crankshaft - Piston

Vilebrequin - Piston

Kurbelwelle - Kolben

Cigüeñal - Pistón

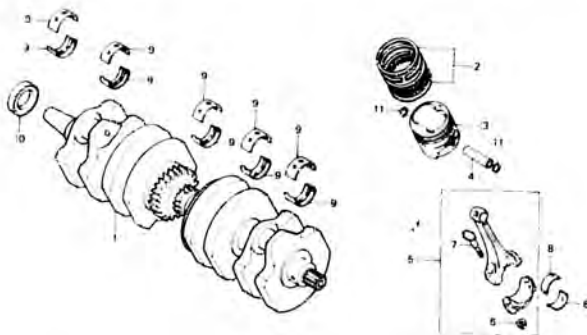

94.06-7

Wartungspunkt	AP	Ref. Nr.	Teile-Nr.	Beschreibung	Menge				Serien-Nr.	Gebiets-Code
					Fz	Fa	Fa	F2c		
KURBELWELLE KOMPL.	*8.3 (+8.6)	1	13000-438-000	KURBELWELLE KOMPL.	1	1	1	1		
KOLBENRING SATZ	*8.2 (+5.5)	2	13000-438-680	KURBELWELLE KOMPL.			1	1		
(JEWELLS 0.2 DAZUZAEHLEN.)			13011-438-004	KOLBENRING SATZ (STD.)	4	4	4	4		
KOLBEN			13021-438-004	KOLBENRING SATZ (0.25)	(4)(4)(4)(4)(4)(4)					
(JEWELLS 0.2 DAZUZAEHLEN.)			13031-438-004	KOLBENRING SATZ (0.50)	(4)(4)(4)(4)(4)(4)					
PLEUELLAGER			13041-438-004	KOLBENRING SATZ (0.75)	(4)(4)(4)(4)(4)(4)					
(JEWELLS 0.3 DAZUZAEHLEN.)	*5.1 (+5.4)	3	13051-438-004	KOLBENRING SATZ (1.00)	(4)(4)(4)(4)(4)(4)					
KOLBENBOLZEN	*7.5 (+7.8)	4	13101-438-000	KOLBEN (STD.)	4	4	4	4		
PLEUELSTANGE KOMPL.			13102-438-000	KOLBEN (0.25)	(4)(4)(4)(4)(4)(4)					
EINSCHL. DAZUGEHÖRIGER TEIL			13103-438-000	KOLBEN (0.50)	(4)(4)(4)(4)(4)(4)					
(JEWELLS 0.2 DAZUZAEHLEN.)	*7.7 (+8.0)	5	13174-438-000	KOLBEN (0.75)	(4)(4)(4)(4)(4)(4)					
LAGER KURBELWELLE			13105-438-000	KOLBEN (1.00)	(4)(4)(4)(4)(4)(4)					
(DIE GLEICHE ARBEITSZEIT-PAUSCHALE - AUCH WENN NUR EIN ODER ALLE TEILE GEWARTET WIRD			13201-438-000	PLEUELSTANGE KOMPL. A	4	4	4	4		
			13201-438-670	PLEUELSTANGE KOMPL. A	4	4	4	4	2202374	

1): F2a F2c TYP



E-15

Crankshaft - Piston

Vilbrequin - Piston

Kurbelwelle - Kolben

Cigüeñal - Pistón

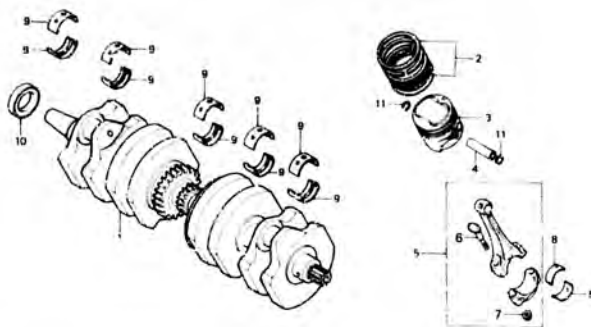

6438-7

Wartungspunkt

AP

Ref. Nr.

Teile-Nr.

Beschreibung

Menge
C8900
Fz Fa Fz Fa Fz Fz

Serien-Nr.

Gebiets-Code

Wahltafel für Pleuellager

II Lagerpiel 20-45 (ml)

Kolben-Lagerspiel	1	2	3
mit Kurbelwelle	0	-0,008	-0,016
mit Pleuellager (C) 204	-0,008	-0,016	-0,025
1	0 +0,008	Gelb	Grün
2	+0,008 +0,016	Grün	Braun
3	+0,016 +0,024	Braun	Schwarz

13202-438-000	PLEUELSTANGE KOMPL. B	▲ ▲								
13202-438-670	PLEUELSTANGE KOMPL. B		▲ ▲							2202374
13203-438-000	PLEUELSTANGE KOMPL. C	▲ ▲		▲ ▲						
13203-438-670	PLEUELSTANGE KOMPL. C		▲ ▲	▲ ▲						2202374
13204-438-000	PLEUELSTANGE KOMPL. D	▲ ▲		▲ ▲						
13204-438-670	PLEUELSTANGE KOMPL. D		▲ ▲	▲ ▲						2202374
13205-438-670	PLEUELSTANGE KOMPL. E			▲ ▲						
13201-438-670	PLEUELSTANGE KOMPL. A				▲ ▲					2202375
13202-438-670	PLEUELSTANGE KOMPL. B				▲ ▲					2202375
13203-438-670	PLEUELSTANGE KOMPL. C				▲ ▲					2202375
13204-438-670	PLEUELSTANGE KOMPL. D				▲ ▲					2202375
13205-438-670	PLEUELSTANGE KOMPL. E				▲ ▲					2202375
6 13204-413-010	SCHRAUBE, PLEUELSTANGE	5	5	5	5	5	5	5	5	
7 13205-438-010	MUTTER, PLEUELSTANGE	5	5	5	5	5	5	5	5	
8 13214-413-004	PLEUPELLAGER A (BLAU) (TAIHD)	5	5	5	5	5	5	5	5	



E-15

Crankshaft • Pleiston

Vlebroquin • Pleiston

Kurbelwelle • Kolben

Cigüefiel • Pleiston

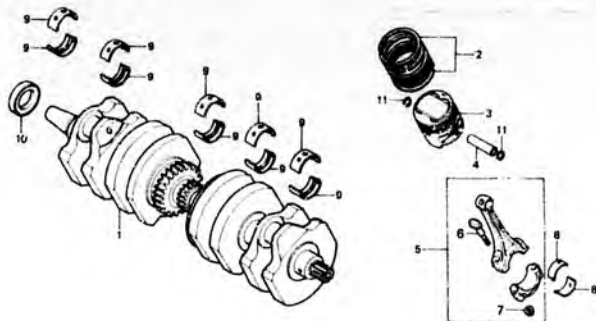

B438-7

Wartungspunkt	AP	Ref. Nr.	Teile-Nr.	Beschreibung	Menge				Serien-Nr.	Gebiets-Code
					Fz	Fa	Fz F2a	Fc F2c		
		13215-413-004		PLEUELLAGER B (SCHWARZ) (TAIHD)	8	8	8	8		
		13216-413-004		PLEUELLAGER C (BRAUN) (TAIHD)	8	8	8	8		
		13217-413-004		PLEUELLAGER D (GRUEN) (TAIHD)	8	8	8	8		
		13218-413-004		PLEUELLAGER E (GELB) (TAIHD)	8	8	8	8		
		9 13315-425-003		LAGER A, KURBELWELLE (SCHWARZ) (DAIDD)	10	10	10	10	10	
		13316-425-003		LAGER B, KURBELWELLE (BRAUN) (DAIDD)	10	10	10	10	10	
		13317-425-003		LAGER C, KURBELWELLE (GRUEN) (DAIDD)	10	10	10	10	10	
		13318-425-003		LAGER D, KURBELWELLE (GELB) (DAIDD)	10	10	10	10	10	
		13319-425-003		LAGER E, KURBELWELLE (BLAU) (DAIDD)	10	10	10	10	10	
		10 91201-425-003		SIMMERING, 25X42X8 (DAIDD)	1	1	1	1	1	

Außenring-Toleranz nach DIN 6201, 200 Kurbelgehäuse 200	A	B	C	
0	-0,008	-0,018	-0,018	
-0,008	-0,016	-0,016	-0,025	
A	D +0,008	Gelb	Grün	Braun
B	+0,008 +0,016	Grün	Braun	Schwarz
C	+0,016 +0,024	Braun	Schwarz	Blau

E 7

E-15

Crankshaft - Piston

Vilebrequin - Piston

Kurbelwelle - Kolben

Cigüerañal - Pistón

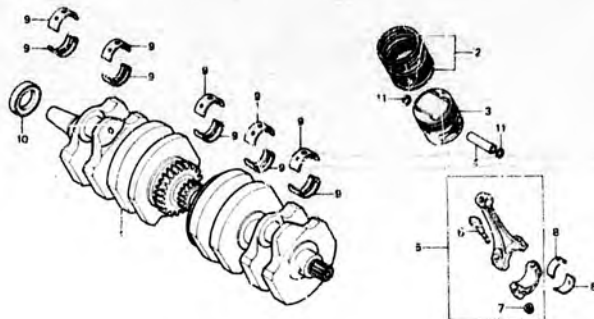

9438-7

Wartungspunkt	AP	Ref. Nr.	Teile-Nr.	Beschreibung	Menge				Serien-Nr.	Gebiets-Code
					Fz	Fa	Fs	Fc		
		11	94601-15000	SICHERUNG, KULBENBOLZEN, 15MM	8	8	1	8	8	8

E 8

E-16

Primary shaft

Arbre primaire

Primäre welle

Eje primario

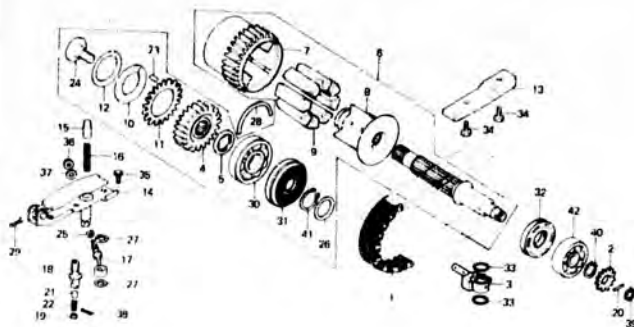

6438-B

Wartungspunkt	AP	Hef. Nr.	Teile-Nr.	Beschreibung	Antrieb				Serien-Nr.	Gebiets-Code
					Fz	Fa	Fz F2a	Fr F2c		
PRIMAERKETTE	=7.2 (=7.6)	1	13610-438-004	PRIMAERKETTE	1	1	1	1	1	1
ANTRIEBSRAD, DELPUMPE	=4.9 (=6.2)	2	15211-425-000	ANTRIEBSRAD, DELPUMPE (17T)	1	1	1	1	1	1
PRIMAERWELLE KOMPL.		3	15710-438-000	ZUFUEHRUNGSDUESE, KETTENDEL	1	1	1	1	1	1
BASIS KOMPL., PRIMAERKETTEN- SPANNER		4	23103-425-300	PRIMAERANTRIEBSZAHNRAD (24T)	1	1	1	1	1	1
SIMMERRING, 25X47X10		5	23105-425-003	HUELSE, PRIMAERANTRIEBSZAHNRAD	1	1	1	1	1	1
ZUFUEHRUNGSDUESE, KETTENDEL	=4.8 (=6.1)	6	23110-438-000	PRIMAERWELLE KOMPL.	1	1	1	1	1	1
DRUCKSTANGE KOMPL., SPANNER		7	23112-425-300	PRIMAERKETTENRAD (28T)	1	1	1	1	1	1
PRIMAERANTRIEBSZAHNRAD	1,0	8	23114-425-300	NABE, ABTRIEDSKETTENRAD	1	1	1	1	1	1
EINSCHL., DAZUGEOERIGER TEIL		9	23115-425-300	DAEMPFGUMMI	8	8	8	8	8	8
PRIMAERKETTENRAD	=6.2 (=6.6)	10	23123-425-300	SEITENPLATTE	1	1	1	1	1	1
NABE, ABTRIEBSKETTENRAD		11	23124-425-300	HILFSZAHNRAD, PRIMAERANTRIEB (23T)	1	1	1	1	1	1
	(: F2a F2c TYP	12	23125-425-005	SCHNEIDENFEDER	1	1	1	1	1	1
		13	23132-393-000	SCHUTZ, PRIMAERKETTE	1	1	1	1	1	1



E-16

Primary shaft

Arbre primaire

Primäre welle

Eje primario

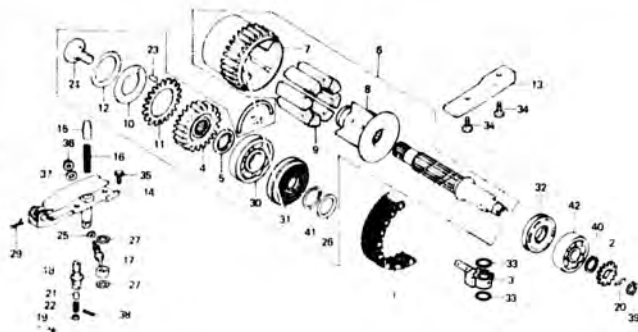

B438 - R

Wartungspunkt	AP	Ref. Nr.	Teile-Nr.	Beschreibung	Menge				Serien-Nr.	Gebiets-Code
					Fz	Fa	Fu	Fc		
DAEMPUNGSGUMMI (DIE GLEICHE ARBEITSZEIT-PAUSCHALE, AUCH WENN NUR EIN ODER ALLE TEILE GEWARTET WIRD)	*5.2 (*5.5)	14	23160-438-000	BASIS KOMPL., PRIMAERKETTEN-SPANNER	1	1	1	1	1	1
ROHR KOMPL., PRIMAERKETTEN-SPANNER	0.9	15	23167-422-010	DRUCKSTANGE KOMPL., SPANNER	1	1	1	1	1	1
KOERPER KOMPL., SPANNERVERTIL	0.8	16	23168-425-000	FEDER, PRIMAERKETTENSPANNER	1	1	1	1	1	1
		17	23175-425-000	ROHR KOMPL., PRIMAERKETTEN-SPANNER	1	1	1	1	1	1
		18	23180-425-000	KOERPER KOMPL., SPANNERVERTIL	1	1	1	1	1	1
		19	23182-425-000	SCHEIBE, ANSCHLAG	1	1	1	1	1	1
		20	24444-300-000	ROLLE, 4X20.6	1	1	1	1	1	1
	(1 : F2a, F2c TYP	21	27611-393-000	RUECKSCHLAGVENTIL, DREHMOMENT- WANDLER-FLUESSIGKEIT	1	1	1	1	1	1
		22	27621-393-000	FEDER, DREHMOMENTWANDLER- FLUESSIGKEITSVENTIL	1	1	1	1	1	1
		23	30905-216-000	STIFT, NOCKENWELLE 3X5.2	1	1	1	1	1	1
		24	90013-425-003	SCHRAUBE, PRIMAERWELLE	1	1	1	1	1	1
		25	90428-425-000	SCHEIBE, 5.2MM	1	1	1	1	1	1

E 10

E-16

Primary shaft

Arbre primaire

Primäre welle

Eje primario

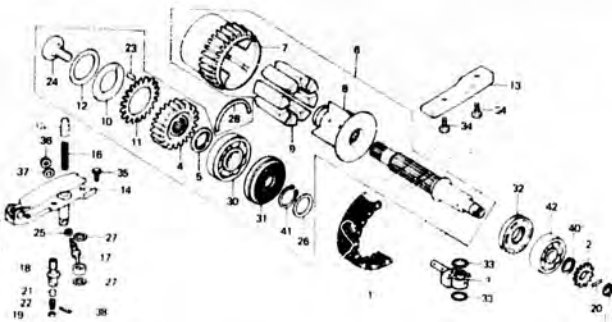

B438 B

Wartungspunkt	AP	Ref. Nr.	Teile-Nr.	Beschreibung	Menge					Serien-Nr.	Gebiets-Code	
					Fz	Fa	Fb	F2a	Fc			F2c
		26	90475-425-000	DRUCKSCHEIBE, 30MM	1	1	1	1	1	1		
		27	90483-700-000	SCHLEIBE, 14MM	2	2	2	2	2	2		
		28	90601-393-000	SICHERUNGSRING 36MM	1	1	1	1	1	1		
		29	90731-425-000	VORSTECKER, 10MM	1	1	1	1	1	1		
		30	91007-438-003	RADIALKUGELLAGER, 63/22	1	1	1	1	1	1		
		31	91201-438-003	SIMMERRING, LÄGER	1	1	1	1	1	1		
		32	91257-425-003	SIMMERRING, 21X47X10	1							2006860
			91257-425-013	SIMMERRING, 23X47X10	1							2006860
			91257-425-004	SIMMERRING, 23X47X10	1							2006861
			91257-425-013	SIMMERRING, 23X47X10	1							2006861
		33	13302-377-000	O-RING, 15X2,5	2	2	2	2	2	2		
		34	92000-06012	SCHRAUBE, HEZ., 6X12	2	2	2	2	2	2		
		35	92000-06014	SCHRAUBE, HEZ., 6X14	3	3	3	3	3	3		

E 11

E-16

Primary shaft

Arbre primaire

Primäre welle

Eje primario

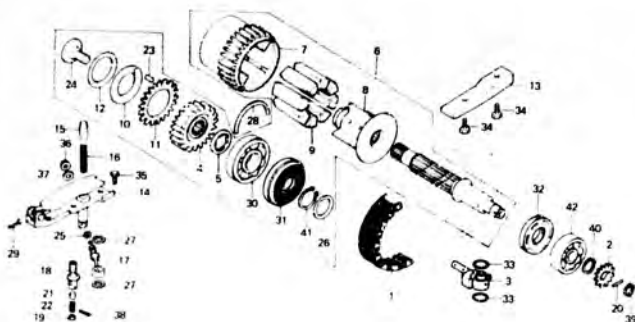

B438-B

Wartungspunkt	AP	Ref. Nr.	Teile-Nr.	Beschreibung	Menge CH800				Serien-Nr.	Gebiets-Code
					F7	Fa	Fa F2a	Fc F2c		
		36	94050-06000	FLANSCHMUTTER, 6MM	1	1	1	1	1	
		37	94101-06000	GLATTE SCHEIBE, 6MM	1	1	1	1	1	
		38	94201-16220	SPLINT, 1.6X22	1	1	1	1	1	
		39	94510-17000	AUSSENSPRENGRING, 17	1	1	1	1	1	
		40	94510-20000	AUSSENSPRENGRING, 20	1	1	1	1	1	
		41	94510-30000	AUSSENSPRENGRING, 30	1	1	1	1	1	1
		42	96100-62040	RADIALKUGELLAGER, 6204	1	1	1	1	1	1

E 12

E-17

Transmission

Transmission

Betriebe

Transmisión

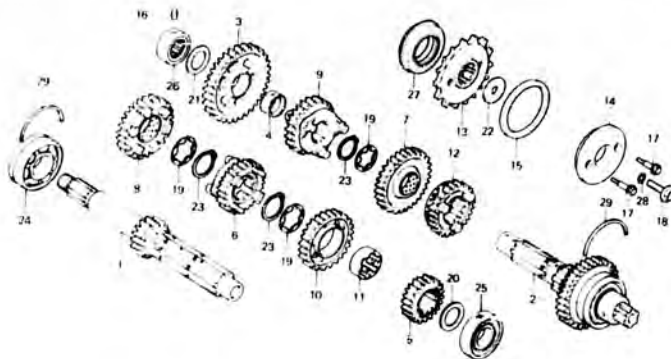

B4.15 - 12

Wartungspunkt	AP	Ref. Nr.	Teile-Nr.	Beschreibung	Menge					Serien-Nr.	Gebiets-Code		
					Fz	Va	Fa	Fz	Fc			F2c	
HAUPTWELLE, GETRIEBE EINSCHL. DAZUGEHÖRIGER TEIL NEBENWELLE KOMPL., GETRIEBE EINSCHL. DAZUGEHÖRIGER TEIL (WENN DIE KOMP. EINHEIT GEWARTET WIRD, BETRAEGT DIE ARBEITSZEIT-PAUSCHALE 5,3 (5,5)) ANTRIEBSKETTENRAD (1): F2a, F2c TYP	*5.1 (05.4) 0,3	1	23211-438-000	HAUPTWELLE, GETRIEBE (15T)	1	1	1	1	1				
		2	21220-438-000	NEBENWELLE KOMPL., GETRIEBE (34T)	1	1							
			23220-438-010	NEBENWELLE KOMPL., GETRIEBE (34T)			1	1			2212471	2212470	
		3	23411-438-000	ERSTES ZAHNRAD, NEBENWELLE (38T)	1	1	1	1	1	1			
		4	23422-425-000	BUCHSE, NEBENWELLE NIEDRIGER GANG	1	1	1	1	1	1			
		5	23431-438-000	ZWEITES ZAHNRAD, HAUPTWELLE (19T)	1	1	1	1	1	1			
		6	23451-438-000	DRITTES ZAHNRAD, HAUPTWELLE (23T)	1								
			23451-438-010	DRITTES ZAHNRAD, HAUPTWELLE (23T)			1	1	1	1	1	2100071	E,ED,F,G DK,DM,SA,U E,ED,F,G E,ED,F,G
				7	23461-438-000	DRITTES ZAHNRAD, NEBENWELLE (32T)	1	1	1	1	1	1	

E 13

E-17

Transmission

Transmission

Getriebe

Transmisión

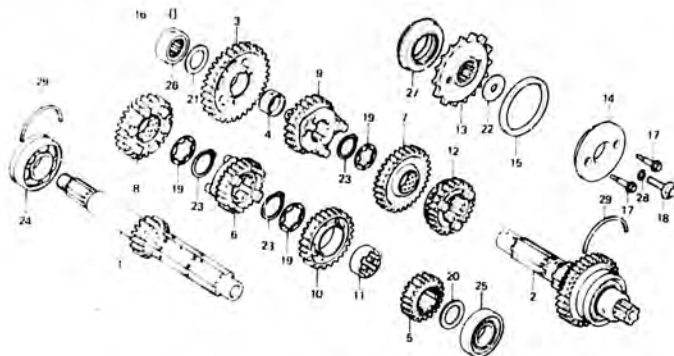

64/58 42

Wartungspunkt	AP	Ref. Nr.	Teile-Nr	Beschreibung	Menge					Serien-Nr.	Gebiets-Code
					Fz	Fa	Fa	Fz	Fz		
		8	23471-438-000	VIERTES ZAHNRAD, HAUPTWELLE (25T)	1						
			23471-438-010	VIERTES ZAHNRAD, HAUPTWELLE (25T)	1					2100071	E, ED, F, G DK, DM, SA, U
			23471-438-020	VIERTES ZAHNRAD, HAUPTWELLE (25T)	1	1	1	1	1	2100072	E, ED, F, G DK, DM, ED, F, U
			23471-438-030	VIERTES ZAHNRAD, HAUPTWELLE (25T)	1	1	1	1	1	2201094	E, G, SA
			23481-438-000	VIERTES ZAHNRAD, NEBENWELLE (29T)	1	1	1	1	1	2201095	DK, DM, ED, F, U E, G, SA
		10	23491-438-000	FUENFTES ZAHNRAD, HAUPTWELLE (27T)	1	1	1	1	1		
		11	23495-422-000	MUTHUELSE, 28X17	1	1	1	1	1		
		12	23501-425-000	FUENFTES ZAHNRAD, NEBENWELLE (27T)	1	1					
			23501-438-670	FUENFTES ZAHNRAD, NEBENWELLE (27T)	1	1				2212471	2212470
								1	1		

E 14

E-17

Transmission

Transmission

Getriebe

Transmisión

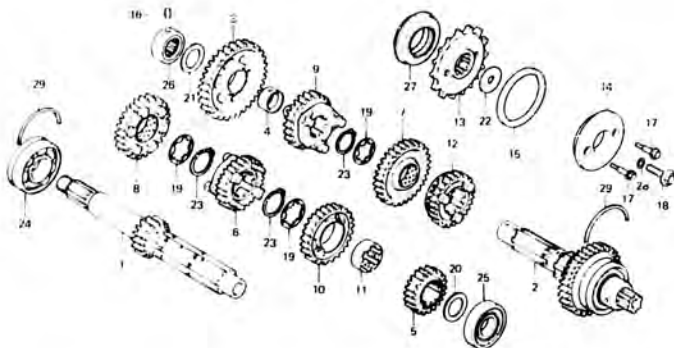

9436-42

Wartungspunkt	AP	Ref. Nr.	Teile-Nr.	Beschreibung	Menge					Serien-Nr.	Gebiets-Code	
					Fz	FA	Fa	F2a	Fc			F2c
		13	23801-438-000	ANTRITZSKFETTENRAD (17T)	1	1	1	1	1	1		
		14	23820-438-000	FUEHRUNG, RING 23820-438-003	1							
		15	23821-438-003	FUEHRUNG, RING	1	1	1	1	1	1		
			23821-438-000	RING, DAEMPFER	1	1						
			23821-460-000	RING, DAEMPFER			1	1	1	1		
		16	24261-283-000	VERBINDUNGSSTIFT, GANGSCHALT- HEBEL	1	1	1	1	1	1		
		17	90020-438-000	FLANSCHENSCHRAUBE, 6X20	2	2	2	2	2	2		
		18	90037-422-000	SPEZIALSCHRAUBE, 10MM	1							
			90037-422-003	SPEZIALSCHRAUBE, 10MM	1						2109496	2109493
		19	90451-422-000	DRUCKSCHEIBE, 28MM	3	3	3	3	3	3		
		20	90453-704-000	DRUCKSCHEIBE, 22MM	1							
			90453-426-000	DRUCKSCHEIBE, 22,5MM	1						2004156	2004155
						1	1	1	1	1		
		21	90457-425-000	DRUCKSCHEIBE, 22MM	1	1	1	1	1	1		
		22	90459-422-000	SCHLEIFE, 10,2MM	1							2008253

E 15

E-17

Transmission

Transmission

Getriebe

Transmisión

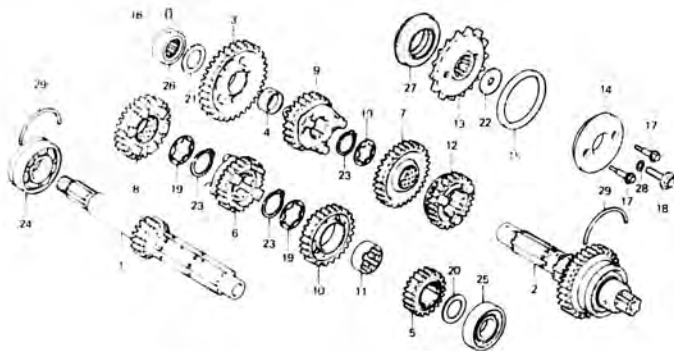

B435-32

Wartungspunkt	AP	Ref. Nr.	Teile-Nr.	Beschreibung	Menge					Serien-Nr.	Gebiets-Code
					Fz	Fa	Fa	Fz	Fz		
			90459-438-000	SCHEIBE, 10.2MM	1					2008254	
		23	90601-422-000	SPRENGRING, 28MM	1	1	1	1	1		
		24	91004-438-003	RADIALKUGELLAGER, 6305	3	3	3	3	3		
		25	91005-475-003	RADIALKUGELLAGER, 63/22U	1	1	1	1	1		
		26	91022-438-008	NADELLAGER, 22MM	1	1	1	1	1		
		27	91203-425-003	SIMMERRING, 40X62X13	1	1	1	1	1		
		25	91352-326-000	O-RING, 9,8X2,4	1	1	1	1	1		
		29	92015-26200	SICHERUNGSRING 620	2	2	2	2	2		
			90602-428-000	SICHERUNGSRING 62MM	2					2111680	

E 16

E-18

Gearshift drum

Tambour de changement de vitesse

Gangschaltwalze

Tambor de cambio

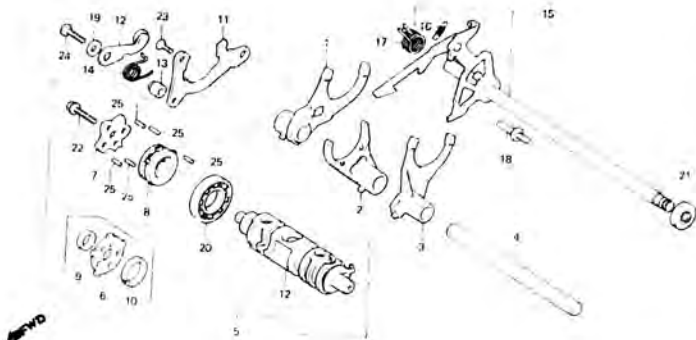

Wartungspunkt	AP	Ref. Nr.	Teile-Nr.	Beschreibung	Menge				Serien-Nr.	Gebiets-Code
					Fz	Fa	Fb	Fc		
GANGSCHALTGABEL KOMPL.	*5.0 (+5.3)	1	24211-425-000	GANGSCHALTGABEL KOMPL., R.	1					
GANGSCHALTWALZE KOMPL.						1				
MITTELPLATTE, SCHALTWALZE	3.7		24211-425-010	GANGSCHALTGABEL KOMPL., R.	1				2107940	2107939
EINSCHL. DAZUGEHÖRIGER TEIL						1	1	1	1	
HALTEPLATTE, GANGSCHALTWALZE		2	24221-425-000	GANGSCHALTGABEL KOMPL., MITTE	1					
STIMMEL KOMPL., GANGSCHALT	0.8					1				2107939
EINSCHL. DAZUGEHÖRIGER TEIL						1				
SIMMERRING, 12,5x25x8	1.0						1	1	1	1
		3	24231-425-000	SCHALTGABEL, L.	1	1	1	1	1	
		4	24261-425-000	WELLE, GANGSCHALTGABEL	1	1	1	1	1	
	() : F2b F2c TYP	5	24300-425-000	GANGSCHALTWALZE KOMPL.	1					2012140
				24300-425-010						
				24300-425-010	1					2012141
				24300-425-030	1					2108239
				GANGSCHALTWALZE KOMPL.		1	1	1	1	

F 4

E-19

**Carburetor
(Assy. - Link)**

**Carburateur
(Ens. - Tringlerie)**

**Vergaser
(Kompl. - Gestänge)**

**Carburador
(Ens. - Articulación)**

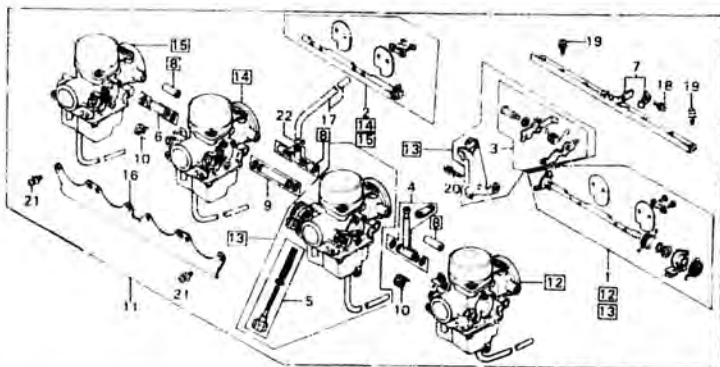

B17-18

Wartungspunkt	AP	Ref. Nr.	Teile-Nr.	Beschreibung	Menge				Serien-Nr.	Gebiets-Code
					Sz	Fa	Fc	F2c		
GELENK SATZ STARTERKLAPPE (JEWELLS 0,2 DAZUZAEHLEN.) BENZINVERBINDER SATZ (JEWELLS 0,2 DAZUZAEHLEN.)	1,7	1	16017-438-305	GELENK SATZ A, STARTERKLAPPE	1					
			16017-438-319	GELENK SATZ A, STARTERKLAPPE	1				VB51A [C]	VB51A [B]
VERGASER KOMPL. 1 (JEWELLS 0,4 DAZUZAEHLEN.) STUETZENPLATTE SATZ, H. BENZINVERBINDER SATZ E VERGASER KOMPL.	0,4 1,3 0,9	2	16018-425-405	GELENK SATZ B, STARTERKLAPPE	1	1	1	1	1	
			16018-445-405	GELENK SATZ B, STARTERKLAPPE	1	1	1	1	1	
		3	16020-425-601	GELENKARM SATZ	1					
			16020-425-602	GELENKARM SATZ	1				VB51A [B]	VB51A [A]
		4	16027-425-671	BENZINVERBINDER SATZ A	1	1	1	1	1	
			16027-444-671	BENZINVERBINDER SATZ A	1	1	1	1	1	
			16028-425-671	SCHRAUBE SATZ B	1	1	1	1	1	
		6	16033-425-671	BENZINVERBINDER SATZ C	1	1	1	1	1	
		7	16035-425-671	STUETZENPLATTE SATZ, H.	1	1	1	1	1	
		[E]	16036-425-671	VERBINDUNG SATZ,	1	1	1	1	1	



E-18

Gearshift drum

Tambour de changement de vitesse

Geangschaltwalze

Tambor de cambio

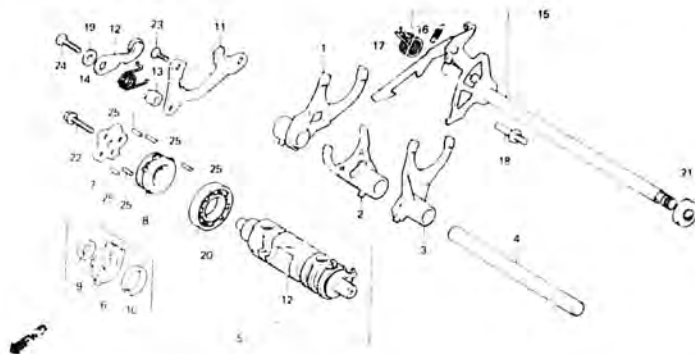

8420-008

Wartungspunkt	AP	Ref. Nr.	Teile-Nr.	Beschreibung	Menge				Serien-Nr.	Gebiets-Code
					F2	FA	F2	F2c		
		6	24302-425-300	MITTELPLATTE, SCHALTWALZE	1					2012140
			24302-425-310	24302-425-310						
			24302-425-310	MITTELPLATTE, SCHALTWALZE	1				2012141	
		7	24303-425-300	NÖCKENSCHLEIBE, GANGSCHALTWALZE	1	1				2106239
			24303-425-310	NÖCKENSCHLEIBE, GANGSCHALTWALZE	1				2106240	2106239
		8	24304-425-300	MITTELTEIL, GANGSCHALTWALZE	1	1	1	1	2108240	
		9	24305-413-000	MUELSE, SCHALTWALZE MITTE	1	1	1	1		
		10	24306-425-300	MUELSE, SCHALTWALZE MITTE	1	1				2106239
					1					2106239
		11	24307-425-000	HALTEPLATTE, GANGSCHALTWALZE	1	1	1	1	1	
		12	24308-413-000	ANSCHLAG KOMPL., GANGSCHALTWALZE	1	1	1	1	1	

F 2

E-18

Gearshift drum

Tambour de changement de vitesse

Geangschaltwalze

Tambor de cambio

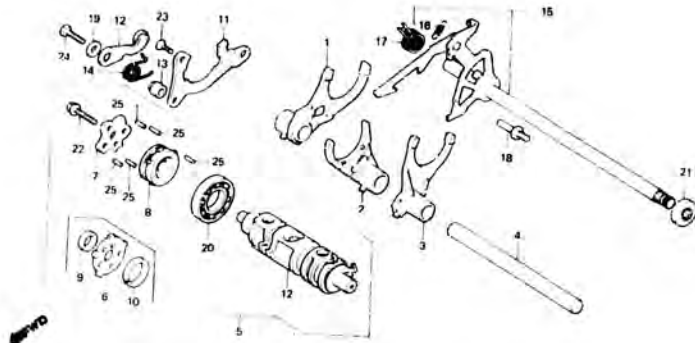

B425 - 140H

Wartungspunkt	AP	Ref. Nr.	Teile-Nr.	Beschreibung	Menge				Serien-Nr.	Gebiets-Code
					Fz	Fa	Fz	Fz		
		13	24432-413-000	HUELSE, SCHALTWALZENANSCHLAG	1	1				
			24432-425-000	HUELSE, SCHALTWALZENANSCHLAG	1	1			2108240	2108239
		14	24435-425-000	ANSCHLAGFEDER, SCHALTWALZE	1	1	1	1	1	
		15	24610-424-000	SPINDEL KOMPL., GANGSCHALT	1	1	1	1	1	
		16	24641-425-000	FEDER, GANGSCHALTARM	1	1	1	1	1	
		17	24651-425-000	GANGSCHALT-RUECKHOLFEDER	1	1	1	1	1	
		18	24652-239-000	STIFT, RUECKHOLFEDER	1	1				2015335
			24652-028-000	STIFT, RUECKHOLFEDER	1	1				2015336
		19	90406-028-000	SCHEIBE, ZUENDVERSTELLER	1	1	4	1	1	
		20	91008-374-003	KUGELLAGER 16005 (TDV0)	1	1	1	1	1	

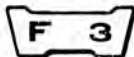

E-18

Gearshift drum

Tambour de changement de vitesse

Geangschaltwalze

Tambor de cambio

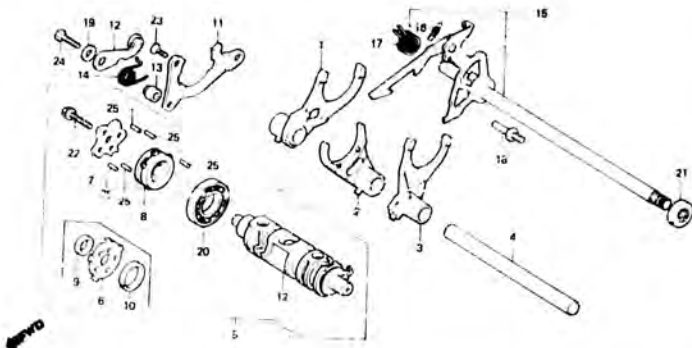

8425-1409

Wartungspunkt	AP	Ref. Nr.	Teile-Nr.	Beschreibung	Menge					Serien-Nr.	Gebiets-Code
					Pz.	Fa.	Fa. C8900	Fc.	Ftc.		
		21	9120A-350-003	SIMMERRING, 12.5X25X8	1	1					
		22	9120A-425-003	SIMMERRING, 12.5X25X8			1	1	1	1	
			92000-06028	SCHRAUBE, HEX., 6X28	1	1					
			92200-06028	SCHRAUBE, HEX., 6X28	1	1				2108240	2108239
		23	93600-06014	FLACHKOPFSCHRAUBE, 6X14	1	1	1	1	1	1	
		24	93725-06025-00	FLANSCHENSCHRAUBE, 6X25	1	1	1	1	1	1	
		25	96220-40118	ROLLE, 4X11.8	5	5	5	5	5	5	

F 4

E-19

Carburetor
(Assy. • Link)

Carburateur
(Ens. • Tringlerie)

Vergaser
(Kompl. • Gestänge)

Carburador
(Ens. • Articulación)

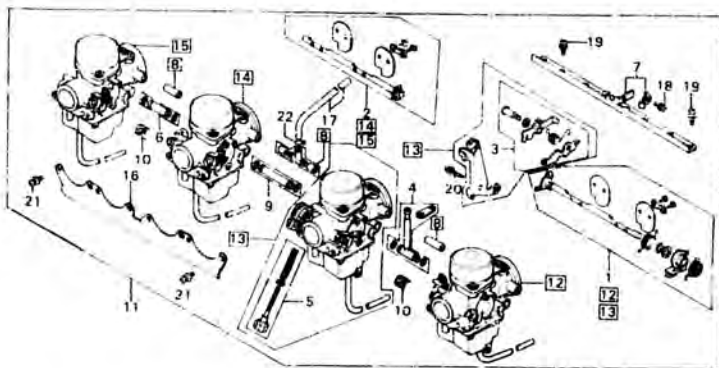

0424-18

Wartungspunkt	AP	Ref. Nr.	Teile-Nr.	Beschreibung	Menge				Serien-Nr.	Gebiets-Code
					Sz	Fa	Fc	F2c		
GELEWK SATZ STARTERKLAPPE (JEWELLS 0,2 DAZUZAEHLEN.) BENZINVERBINDER SATZ (JEWELLS 0,2 DAZUZAEHLEN.)	1,7	1	16017-438-305	GELENK SATZ A, STARTERKLAPPE	1				VB51A [C]	VB51A [B]
			16017-438-319	GELENK SATZ A, STARTERKLAPPE	1					
VERGASER KOMPL. 1 (JEWELLS 0,4 DAZUZAEHLEN.) STUETZENPLATTE SATZ, H. BENZINVERBINDER SATZ E VERGASER KOMPL.	0,4 1,3 0,9	2	16017-438-355	GELENK SATZ A, STARTERKLAPPE	1	1	1	1	VB51A [C]	VB51A [B]
			16018-425-405	GELENK SATZ B, STARTERKLAPPE	1	1	1	1		
		3	16018-445-405	GELENK SATZ B, STARTERKLAPPE	1	1	1	1	VB51A [B]	VB51A [A]
			16020-425-601	GELENKARM SATZ	1					
			16020-425-602	GELENKARM SATZ	1					
		4	16027-425-671	BENZINVERBINDER SATZ A	1	1	1	1		
			16027-440-671	BENZINVERBINDER SATZ A	1	1	1	1		
		5	16028-425-671	SCHRAUBE SATZ B	1	1	1	1		
		6	16033-425-671	BENZINVERBINDER SATZ C	1	1	1	1		
		7	16035-425-671	STUETZENPLATTE SATZ, H.	1	1	1	1		
		8	16036-425-671	VERBINDUNG SATZ,	1	1	1	1		

F 5

E-19

Carburetor
(Assy. • Link)

Carburateur
(Ens. • Tringlerie)

Vergaser
(Kompl. • Gestänge)

Carburador
(Ens. • Articulación)

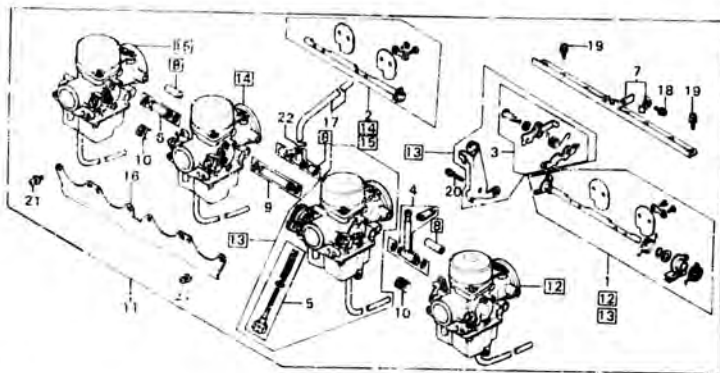

B425-10

Wartungspunkt	AP	Ref. Nr.	Teile-Nr.	Beschreibung	Menge					Serien-Nr.	Gebiets-Code	
					Fz	Fa	Fa F2a	Fc	F2c			
		9	16037-425-571	BENZINVERBINDER SATZ E	1	1	1	1	1			
		10	16051-413-004	DRUCKSPULENFEDER	2	2	2	2	2			
		11	16100-436-003	VERGASER KOMPL.	1							
			16100-436-013	VERGASER KOMPL.	1					2102627	2102626	
			16100-436-023	VERGASER KOMPL.	1					2108074	2108073	
			16100-436-601	VERGASER KOMPL.		1					2201797	E, G, SA DK, DM, ED, F, U
			16100-436-602	VERGASER KOMPL.		1	1	1	1		2201798	E, G, SA E, G, SA
		12	16101-436-305	VERGASER KOMPL. 1	1			1	1			
			16101-436-315	VERGASER KOMPL. 1		1				VB51A	VB51A A	
			16101-436-325	VERGASER KOMPL. 1		1				VB51A B	VB51A B	
			16101-436-335	VERGASER KOMPL. 1		1				VB51A C	VB51A C	
			16101-436-345	VERGASER KOMPL. 1		1	1	1	1		VB51A D	E, C, SA DK, DM, ED, F, U
						1				VB51 E	E, G, SA E, S, SA	
							1	1	1			

F 6

E-19

Carburetor
(Assy. • Link)

Carbureteur
(Ens. • Tringlerie)

Vergaser
(Kompl. • Gestänge)

Carburador
(Ens. • Articulación)

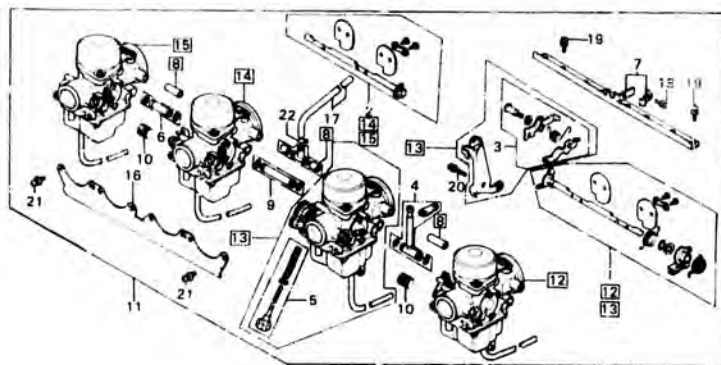

B425-18

Wartungspunkt	AP.	Ref. Nr.	Teile-Nr.	Beschreibung	Menge				Serien-Nr.	Gebiets-Code	
					Fz	Fa	Fc	F2c			
		13	16102-438-305	VERGASER KOMPL. 2	1						
			16102-438-315	VERGASER KOMPL. 2	1				VB51A B	VB51A A	
			16102-438-322	VERGASER KOMPL. 2	1				VB51A C	VB51A B	
			16102-438-335	VERGASER KOMPL. 2		1	1	1		VB51A D	E, G, SA DK, DM, ED, F, U
			16102-438-345	VERGASER KOMPL. 2		1			VB51 E	E, G, SA	
		14	16103-436-305	VERGASER KOMPL. 3	1						
			16103-436-315	VERGASER KOMPL. 3		1			VB51A B	VB51A A	
			16103-436-329	VERGASER KOMPL. 3		1			VB51A C	VB51A B	
			16103-436-335	VERGASER KOMPL. 3		1	1	1		VB51A D	E, G, SA DK, DM, ED, F, U
			16103-436-345	VERGASER KOMPL. 3		1			VB51 E	E, G, SA	
		15	16104-438-305	VERGASER KOMPL. 4	1						
			16104-438-315	VERGASER KOMPL. 4		1			VB51A B	VB51A A	
			16104-438-325	VERGASER KOMPL. 4		1			VB51A C	VB51A B	
			16104-438-335	VERGASER KOMPL. 4		1	1	1		VB51A D	E, G, SA



E-19

Carburetor
(Assy. • Link)

Carburateur
(Ens. • Tringlerie)

Vergaser
(Kompl. • Gestänge)

Carburador
(Ens. • Articulación)

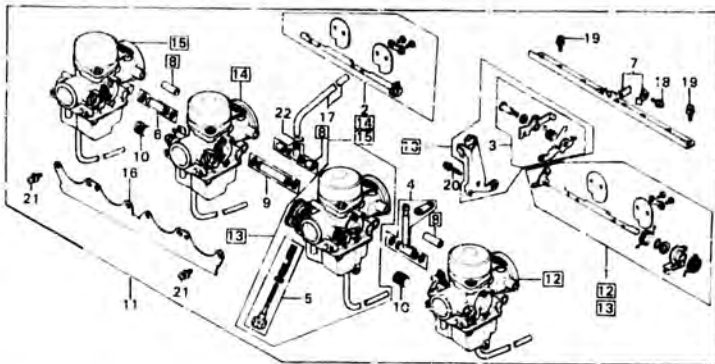

5425 1/4

Wartungspunkt	AP	Ref. Nr.	Teile-Nr.	Beschreibung	Atenge C890C				Serien-Nr.	Gebiets-Code
					Fz	Fa	Fa F2a	Fc F2c		
		16104-438-345	VERGASER KOMPL. 4		1		1			
									VB51 [E]	DK,DM,ED,F,U E,G,SA DK,DM,ED,F,U E,G,SA
	16	16119-425-671	STUETZENPLATTE		1					
		16119-425-672	STUETZENPLATTE		1				VB51A [E]	VB51A [A]
	17	16199-425-671	BENZINSCHLAUCH		1	1	1	1	1	
	18	93892-04012-00	SCHRAUBE MIT SCHEIBE, 4X12		1	1	1	1	1	
	19	93892-05012-00	SCHRAUBE MIT SCHEIBE, 5X12		0	0	0	0	0	
	20	93892-05016-00	SCHRAUBE MIT SCHEIBE, 5X16		1	1	1	1	1	
	21	93892-06014-00	SCHRAUBE MIT SCHEIBE, 6X14		0	0	0	0	0	
	22	95002-02080	KL'EME B8, SCHLAUCH		1	1	1	1	1	

F 8

E-19-1

**Carburator
(Component parts)**

**Carburateur
(Pièces composantes)**

**Vergaser
(Einzelteil)**

**Carburador
(Piezas componentes)**

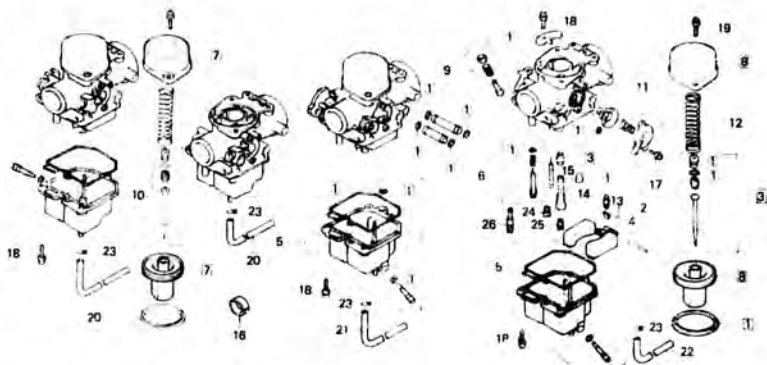

9436-43A

Wartungspunkt	AP	Ref. Nr.	Teile-Nr.	Beschreibung	Metric				Serien-Nr.	Gebiets-Code
					Fz	FA	Fa	Fc		
DICHTUNG SATZ (JEWELLS 0,4 DAZUZAEHLEN.)	2+1	[1]	16010-425-601	DICHTUNG SATZ	4	4	4	4	4	
SCHWIMMVENTIL SATZ (JEWELLS 0,2 DAZUZAEHLEN.)	1+0	2	16011-382-004	SCHWIMMVENTIL SATZ	4	4	4	4	4	V851A [A]
SCHWIMMER SATZ (JEWELLS 0,2 DAZUZAEHLEN.)		[5]	16012-438-007	DUESENNADELSATZ	4	4	4	4	4	
SCHWIMMVENTIL (JEWELLS 0,2 DAZUZAEHLEN.)		4	16013-679-005	SCHWIMMER SATZ	4	4	4	4	4	
SCHWIMMERKAMMER SATZ (JEWELLS 0,2 DAZUZAEHLEN.)			16013-413-751	SCHWIMMER SATZ	4	4	4	4	4	V551A [B]
DUESENNADELSATZ (JEWELLS 0,2 DAZUZAEHLEN.)	1+1	5	16015-413-004	SCHWIMMERKAMMER SATZ	2	2	2	2	2	
SCHWIMMERKAMMER SATZ (L. SEITE 0,3)	0+2	6	16016-410-601	SCHRAUBE SATZ A	4	4	4	4	4	
VAKUUMKOLBEN SATZ		[7]	16022-413-014	VAKUUMKOLBEN SATZ	2	2	2	2	2	V851A [A]
LUFTABSCHLUSSVENTIL SATZ	0+1		15044-425-771	VAKUUMKOLBEN SATZ	2	2	2	2	2	V851A [B]
HALTER, NADELDUESE (JEWELLS 0,2 DAZUZAEHLEN.)	0+5	[8]	16022-413-014	VAKUUMKOLBEN SATZ	2	2	2	2	2	V851A [A]
PRIMAERHAUPTDUESE, #68 (JEWELLS 0,2 DAZUZAEHLEN.)			16022-413-891	VAKUUMKOLBEN SATZ	2	2	2	2	2	V851A [B]
		9	16029-413-004	SCHRAUBE SATZ C	3	3	3	3	3	
		10	16045-425-671	SCHWIMMERKAMMER SATZ C	2	2	2	2	2	

F 9

E-19-1

Carburator
(Component parts)

Carbureteur
(Pièces composantes)

Vergaser
(Einzelteil)

Carburador
(Piezas componentes)

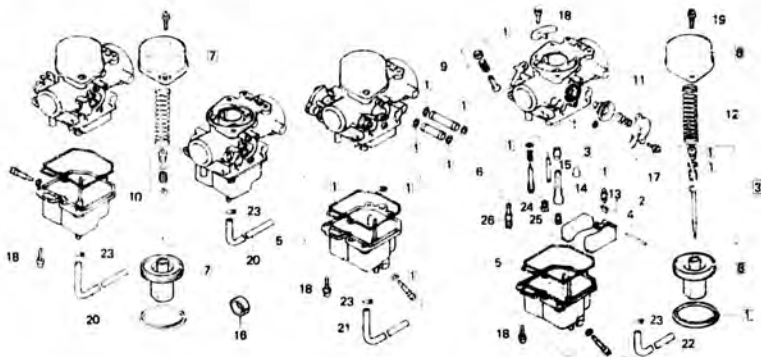

9436 - 436

Wartungspunkt	AP	Ref. Nr.	Teile-Nr.	Beschreibung	Menge				Serien-Nr.	Gebiets-Code
					Fz	Fa	Fc	F2c		
		11	16048-423-671	LUFTABSCHLUSSVENTIL SATZ	4	4				
			16048-429-771	LUFTABSCHLUSSVENTIL SATZ					VB51A [B]	VB51A [A]
		12	16050-443-721	FEDER, VAKUUMKOLBEN	4	4	4	4		
		13	16153-413-751	SCHWIMMERVENTIL	4	4	4	4	VB51A [B]	
		14	16165-438-003	HALTER, NADELDUESE	4	4	4	4		
		15	16166-438-003	HAUPTDUESE	4	4	4	4		
		16	16291-300-300	GUMMIBAND	1	1	1	1		
		17	93892-04012-00	SCHRAUBE MIT SCHEIBE, 4X12	8	8	8	8		
		18	93892-04016-00	SCHRAUBE MIT SCHEIBE, 4X16	16	16	16	16		
		19	93892-05016-00	SCHRAUBE MIT SCHEIBE, 5X16	8	8	8	8		
		20	95001-35480-40	BENZINSCHLAUCH, 3,5X480	2					
			16144-413-751	UEBERLAUFSCHLAUCH	2				VB51A [B]	VB51A [A]
						2	2	2		
		21	95001-35550-40	BENZINSCHLAUCH, 3,5X550	1					VB51A [A]
						1				

F 10

E-19-1

**Carburetor
(Component parts)**

**Carburateur
(Pièces composantes)**

**Vergaser
(Einzelteil)**

**Carburador
(Piezas componentes)**

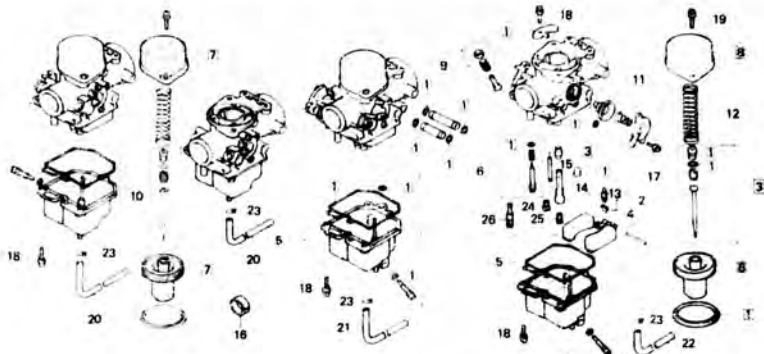

9-138-1-33A

Wertungspunkt	AP	Ref. Nr.	Teile-Nr.	Beschreibung	Menge				Serien-Nr.	Gebiets-Code
					Fz	Fa	Fz	Fz		
			16195-449-771	BENZINSCHLAUCH	1				V851A [B]	
		22	95001-35623-40	BENZINSCHLAUCH, 3,5X610	1	1	1	1		
			16198-425-671	BENZINSCHLAUCH		1			V851A [B]	V851A [A]
		23	95002-02070	KLEMME B7, SCHLAUCH			1	1		
			95002-02630	KLEMME B6.5, SCHLAUCH					V851A [B]	V851A [A]
		24	99101-393-0680	PRIMAERHAUPTDUESE, #68		4	4	4		
		25	99102-393-0980	SEKUNDAERHAUPTDUESE, #98		4	4	4		
		26	99103-441-0420	LEERLAUFDUESE #42		4	4			
			99103-441-0420	LEERLAUFDUESE #42						

F 11

E-20

**Automatic fuelcock
(CB900Fs - F2s - Fc - F2c)**

**Robinet d'essence automatique
(CB900Fs - F2s - Fc - F2c)**

**Automatischer Benzinhahn
(CB900Fs - F2s - Fc - F2c)**

**Grifo de combustible automático
(CB900Fs - F2s - Fc - F2c)**

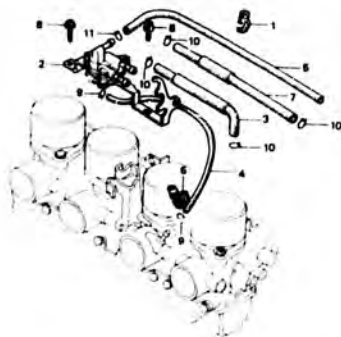

B461 - 38

Wartungspunkt	AP	Ref. Nr.	Teile-Nr.	Beschreibung	Mengz CB900					Serien-Nr.	Gebiets-Code
					Fz	Fa	Fs	Fc	F2c		
SELBSTBENZINHAHN KOMPL. BENZINSCHLAUCH, 7,3X235 (DIE GLEICHE ARBEITSZEIT- PAUSCHALE, AUCH WENN NUR EIN	0.3	1	16876-671-650	KLAMMER A, SCHLAUCH	1	1	1	1	1		
	0.2	2	16970-461-772	SELBSTBENZINHAHN KOMPL.	1	1					
		3	16970-461-751	SELBSTBENZINHAHN KOMPL.				1	1		
		3	16971-461-771	BENZINSCHLAUCH, 7,3X200	1	1	1	1	1		
		4	16972-461-771	VAKUUMSCHLAUCH	1	1	1	1	1		
		5	16973-461-771	LUFTABZUGSCHLAUCH, 3X360	1	1	1	1	1		
		6	16976-461-771	KLAMMER, SCHLAUCH	1	1	1	1	1		
		7	16990-461-771	BENZINSCHLAUCH, 7,3X235	1	1					
			16990-461-750	BENZINSCHLAUCH, 7,3X225	1	1		1	1		
		6	93892-05016-00	SCHRAUBE MIT SCHEIBE, 5X16	2	2	2	2	2		
		9	95002-02070	KLEMME 37, SCHLAUCH	2	2	2	2	2		
	10	95002-02120	KLEMME B12, SCHLAUCH	4	4	4	4	4			
		11	95002-02650	KLEMME B6.5, SCHLAUCH	1	1	1	1	1		

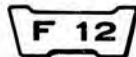

EOP-1

Gasket kit A

Trousse de joint A

Dichtung Satz A

Equipode empacadura A

Wartungspunkt	AP	Ref. Nr.	Teile-Nr.	Beschreibung	Menge					Serien-Nr.	Gebiets-Code	
					Fz	Fa	Fb	F2a	Fc			F2c
		1	06110-438-010	DICHTUNG SATZ A	1							
			061A1-438-000	DICHTUNG SATZ A	1							
			06110-438-020	DICHTUNG SATZ A	1					2104728		2104727
			061A1-438-010	DICHTUNG SATZ A (COMPONENT PARTS)			1	1	1	1		
			12191-425-010	DICHTUNG, ZYLINDER	1	1	1	1	1	1		
		2	12209-422-005	DICHTUNG, VENTILSCHAF	16	16	16	16	16	16		
		3	12251-438-013	DICHTUNG, ZYLINDERKOPF	1	1	1	1	1	1		
		4	12391-425-000	DICHTUNG, ZYLINDERKOPFDECKEL	1	1						
			12391-425-010	DICHTUNG, ZYLINDERKOPFDECKEL								
		5	18291-254-000	DICHTUNG, AUSPUFFROHR	4	4	4	4	4	4		
		6	91302-425-000	O-RING, 66,8X2	4	4	4	4	4	4		
		7	91307-422-000	O-RING, 4,9X1,9	1							
			91313-393-003	O-RING, 7,8X2,2	1							
							1	1	1	1	2104728	2104727

F 13

EOP-1

Gasket kit A

Trousse de joint A

Dichtung Satz A

Equipode empacadura A

Wartungspunkt	AP	Ref. Nr.	Teile-Nr.	Beschreibung	Menge				Serien-Nr.	Gebiets-Code
					F1	F2	F3	F4		
		8	91311-425-000	O-RING, NOCKENWELLEHALTER	1	1	1	1	1	

F 14

EOP-2

Gasket kit B

Trousse de joint B

Dichtung Satz B

Equipode empacadura B

Wartungspunkt	AP	Ref. Nr.	Teile-Nr.	Beschreibung	Menge					Serien-Nr.	Gebiets-Code
					Fz	Fa	Fs	Fc	FzC		
		1	06111-438-000	DICHTUNG SATZ B	1						
			06111-438-010	06111-438-010 DICHTUNG SATZ B	1	1					2100007
				(COMPONENT PARTS)						2100008	
			11359-425-000	DICHTUNG, DELPUMPENDECKEL	1	1	1	1	1		
			11359-425-020	DICHTUNG, DELPUMPENDECKEL	1						2100008
		2	11395-425-000	DICHTUNG, L. SEITENDECKEL	1	1	1	1	1		
		3	11396-425-000	DICHTUNG, KUPPLUNGSDECKEL	1	1	1	1	1		
		4	11398-425-000	DICHTUNG, DELWANNE	1	1	1	1	1		
		5	11691-425-000	DICHTUNG, A.C. GENERATORDECKEL	1						
			11691-425-010	DICHTUNG, A.C. GENERATORDECKEL	1						2103517
						1	1	1	1		2103517
		6	30372-425-000	DICHTUNG, KONTAKTDECKEL	1	1	1	1	1		
		7	91301-250-000	O-RING, 22X3.0	1	1	1	1	1		

F 15

EOP-2

Gasket kit B

Trousse de joint B

Dichtung Satz B

Equipode empacadura B

Wartungspunkt	AP	Ref. Nr.	Teile-Nr.	Beschreibung	Menge				Serien-Nr.	Gebiets-Code
					C8000	Fz	Fa	Fc		
		5	91302-001-07G	O-RING, 30,8MM	1	1	1	1	1	
		9	91302-377-00U	O-RING, 15X2,5	3	3	3	3	3	
		10	91305-639-000	O-RING, 9,5X3	4	4	4	4	4	DK,DM,E,ED,G,SA,U
					4	4	4	4	4	F
										2215479
										DK,DM,E,ED,G,SA,U
		11	91305-714-000	O-RING, 24MM	1	1	1	1	1	
		12	91306-329-000	O-RING, 16X1,9	1	1	1	1	1	
		13	91306-654-000	O-RING, 17X3,5MM	1	1	1	1	1	
		14	91309-300-000	O-RING, 24,4X3,1	1	1	1	1	1	
		15	91316-300-003	O-RING, 89X4,5	1	1	1	1	1	
		16	91352-526-000	O-RING, 9,8X2,4	1	1	1	1	1	
		17	94608-40000	O-RING, 19,4X2,8	1	1	1	1	1	