

C 1

# BLOCKINDEX - MOTORGRUPPE



- E 1 Ölwanne
- E 2 Zylinderkopfdeckel
- E 3 Zylinderkopf
- E 4 Nockenwellen-Ventile
- E 5 Steuerkette-Spanner
- E 8 Zylinder

- C 7
- C 3
- C 2
- S 1
- C 1
- S 16

- E 7 Luftmaschine-Dynamolücke
- E 8 Kupplungsstock
- E 9 Kupplung
- E 10 Linker Deckel-Zündventiltrieb
- E 11 Anlassermotor
- F 12 Linker Kurbelgehäuseteil-Ölpumpe
- E 13 Ölfilter-Gelwanne
- E 14 Kurbelgehäuse

- D 1
- D 7
- D 6
- D 7
- D 9
- D 12
- D 15
- E 1

- E 15 Kurbelwelle-Einbaueinheit
- E 16 Primärwelle
- E 17 Getriebe
- E 18 Gangschaltwalze
- E 19 Vergaser-Kompl.-Gestänge
- E 19-1 Vergaser (Einzelteil)
- E 20 Autom. atisches Benzinohr
- EOP 1 Dichtung Satz A
- EOP 2 Dichtung Satz B

- E 4
- E 8
- E 12
- E 16
- F 2
- F 8
- F 11
- F 12
- F 14



D 2

E-7

Generator - Dynamo cover

Générateur - Couverture générateur

Lichtmaschine - Dynamodeckel

Generador - Cubierta de generador

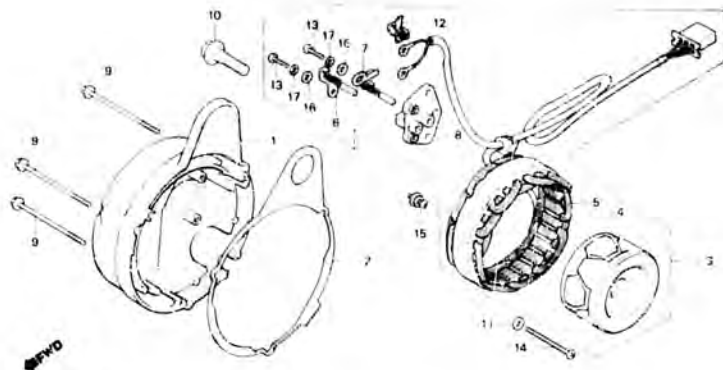

6411

Wartungspunkt	AP	Ref. Nr.	Teil. Nr.	Beschreibung	Menge				Serien-Nr	Gebiets-Code
					Fr	Fa	Er	F2c		
		11	90563-304-000	BEFESTIGUNGSSCHEIBE, NUMMERN-SCHILD	3	3	3	3		
		12	90659-170-000	KABELKLEBME	1	1	1	1		
		13	93500-04012-00H	KEGELKOPFSCHRAUBE, 4x12	2	2	2	2		
		14	93500-06045	KEGELKOPFSCHRAUBE, 6x45	3	3	3	3		
		15	93892-36014-00	SCHRAUBE MIT SCHEIBE, 6X14	2	2				
			93493-06016-00	SCHRAUBE MIT SCHEIBE, 6X16			2	2		
			91492-425-000	SCHRAUBE MIT SCHEIBE, 6X16			2	2	2215A09	2216A08
		16	94101-04900	GLATTE SCHEIBE, 4MM	2	2	2	2		
		17	94111-04800	FEDERRING, 4MM	2	2	2	2		

D 3

E-8

Clutch cover

Couvercle d'embrayage

Kupplungsdeckel

Cubierta de embrague

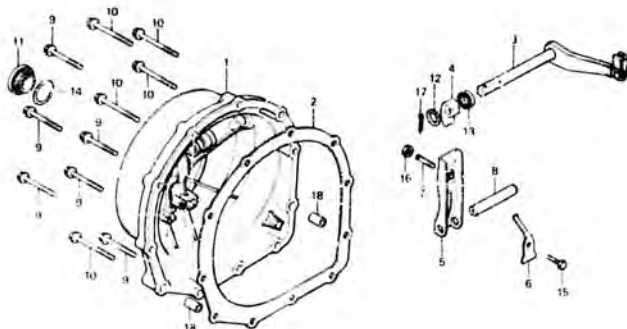

B438 2

Wartungspunkt	AP	Ref. Nr.	Teile-Nr.	Beschreibung	Range C8900				Serial-Nr.	Gebiets-Code
					F1	FA	F2	F2c		
KUPPLUNGSDECKEL KOMPL. KUPPLUNGSEBEL KOMPL. EINSCHL. DAZUGEHÖRIGER TEIL	0.5	1	21330-423-000	KUPPLUNGSDECKEL KOMPL.	1	1	1	1		
			11330-428-670	KUPPLUNGSDECKEL KOMPL.	1	1	1	1	1	1
EINSTELLHEBEL, KUPPLUNG	0.4	2	22710-438-000	KUPPLUNGSEBEL KOMPL.	1	1	1	1	1	1
		3	22821-107-000	NÖCKEN, KUPPLUNGSEBEL	1	1	1	1	1	1
DICHTUNG, KUPPLUNGSDECKEL	0.4	4	22831-425-000	EINSTELLHEBEL, KUPPLUNG	1	1	1	1	1	1
		6	22835-425-070	HALTEPLATTE, KUPPLUNGSEBEL	1	1	1	1	1	1
		7	22841-425-000	EINSTELLSCHRAUBE, KUPPLUNG	1	1	1	1	1	1
		8	28106-422-007	WELLE, ANLASSERREDUKTIONSTRIEBWELLE, FAHRRAD	1	1	1	1	1	1
		9	90006-415-000	FLANSCHENSCHRAUBE, 6X32 96000-06032-00		6				
		10	96000-06032-00	FLANSCHENSCHRAUBE, 6X32		6	6	6	6	6
			90007-428-000	FLANSCHENSCHRAUBE, 6X40		5				
			96000-06040-00	FLANSCHENSCHRAUBE, 6X40		5	5	5	5	5
			96000-06040-00	FLANSCHENSCHRAUBE, 6X40		5	5	5	5	5
		11	9002-422-000	KAPPE, KUPPLUNGSEINSTELLUNG	1	1	1	1	1	1

D 4

E-8

Clutch cover

Couvercle d'embrayage

Kupplungsdeckel

Cubierta de embrague

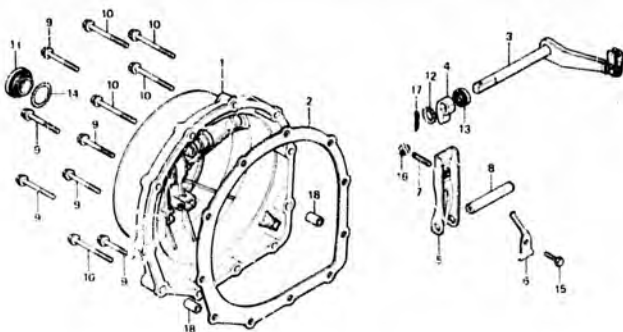

9438 - 2

Wartungspunkt	AP	Ref. Nr.	Teile-Nr.	Beschreibung	Menge				Serien-Nr.	Gebiets-Code
					Fz	Fa	Fa F2a	Fc F2c		
		12	9C471-333-000	SCHEIBE, 10MM	1	1	1	1	1	
		13	91206-333-003	SINNHERRING, 10X16X4,5	1	1	1	1	1	
		14	91303-714-000	O-RING, 24MM	1	1	1	1	1	
		15	92000-06012	SCHRAUBE, HEX., 6X12	1	1	1	1	1	
		16	94001-06000	MUTTER, HEX., 6MM	1	1	1	1	1	
		17	94201-20150	SPLINT, 2.0X15	1	1	1	1	1	
		18	92201-02140	PASSTIFT A, 8X14	2	2	2	2	2	

D 5

E-9

Klutch

Embrayage

Kupplung

Embrague

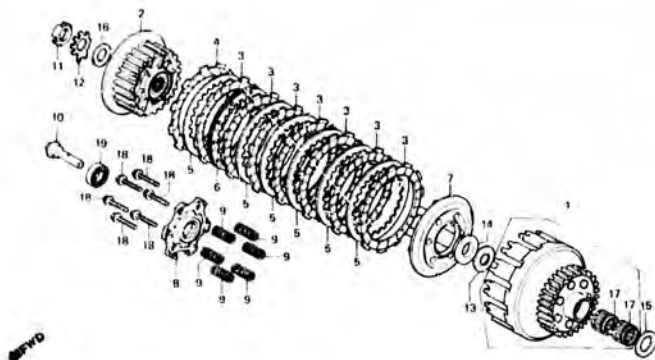

B425 - B

Wartungspunkt	AP	Ref. Nr.	Teile-Nr.	Beschreibung	Menge				Serien-Nr.	Gebiets-Code
					Fz	Fa	Fc	F2c		
KUPPLUNGSKORB KOMPL. EINSCHL. DAZUGEHÖRIGER TEIL	0.7	1	22100-438-000	KUPPLUNGSKORB KOMPL.	1	1	1	1	1	1
		2	22120-425-000	KUPPLUNGSNABE	1	1	1	1	1	1
		3	22201-425-000	REIBSCHEIBE A, KUPPLUNG	7	7	7	7	7	7
		4	22202-425-000	REIBSCHEIBE B, KUPPLUNG	1	1	1	1	1	1
		5	22321-425-000	KUPPLUNGSPLATTE	6	6	6	6	6	6
REIBSCHEIBE A, KUPPLUNG EINSCHL. DAZUGEHÖRIGER TEIL (DIE GLEICHE ARBEITSZEIT-PAUSCHALE, AUCH WENN NUR EIN ODER ALLE TEILE GEWARTET WIRD)	0.5	6	22322-425-000	KUPPLUNGSPLATTE KOMPL. B	1	1	1	1	1	1
		7	22350-425-000	DRUECKPLATTE, KUPPLUNG	1	1	1	1	1	1
		8	22361-425-000	PLATTE, KUPPLUNGSHEBER	1	1	1	1	1	1
		9	22401-422-000	KUPPLUNGSFEDER	6	6	6	6	6	6
KUPPLUNGSHEBER (DIE GLEICHE ARBEITSZEIT-PAUSCHALE, AUCH WENN NUR EIN ODER ALLE TEILE GEWARTET WIRD)	0.4	10	22843-425-000	FUEHRUNG, KUPPLUNGSHEBER	1	1	1	1	1	1
		11	90231-200-010	GEGENMUTTER, 16MM	1	1	1	1	1	1
KUPPLUNGSHEBER (DIE GLEICHE ARBEITSZEIT-PAUSCHALE, AUCH WENN NUR EIN ODER ALLE TEILE GEWARTET WIRD)	0.4	12	90431-292-000	SICHERUNGSSCHEIBE, 16MM	1	1	1	1	1	1
		13	90432-371-000	MUTSCHEIBE, 23MM	1	1	1	1	1	1
		14	90432-425-000	MUELSE, KUPPLUNG	1	1	1	1	1	1
		15	90435-333-010	DRUCKSCHEIBE, 23MM	1	1	1	1	1	1

D 6

E-9

Clutch

Embrayage

Kupplung

Embrague

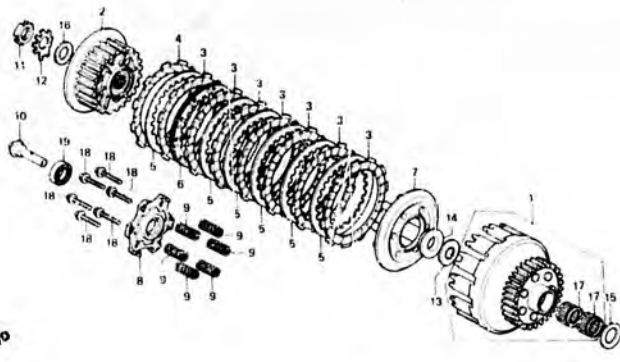

8425-8

Wartungspunkt	A <sup>1</sup>	Ref. Nr.	Teile-Nr.	Beschreibung	Menge				Serien-Nr.	Gebiets-Code
					Fz	Pa	Fa	F2a		
		16	90481-292-000	SICHERUNGSSCHEIBE, DELFILTERRUTOR	1	1	1	1	1	1
		17	91010-3-0-008	NADELLAGER, 25X32X20	2	2	2	2	2	2
		18	93725-06025-00	FLANSCHENSCHRAUBE, 6X23	6	6	6	6	6	6
		19	96100-60030	RADIALKUGELLAGER, 5003	1	1	1	1	1	1

**D 7**

**E-10**

Left cover - Advancer

Couvercle gauche - Avance

Linker Deckel - Zündversteller

Cubierta Izquierda - Avanzador

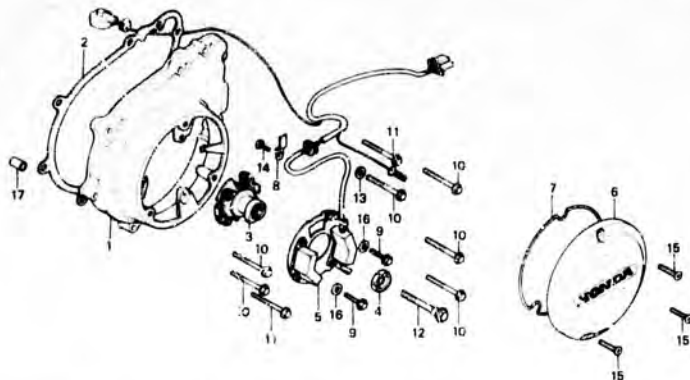

B436-3a

Wartungspunkt	AP	Ref. Nr.	Teile-Nr.	Beschreibung	Menge				Serien-Nr.	Gebiets-Code
					Fz	Fz	Fz	Fz		
KURBELGEMAEUSEDECKEL, L. DICHTUNG, L. SEITENDECKEL ZUENDVERSTELLER KOMPL. IMPULSGENERATOR KOMPL. DECKEL, KONTAKT	0.4	1	11341-425-000	KURBELGEMAEUSEDECKEL, L.	1					
	0.3		11341-425-010	KURBELGEMAEUSEDECKEL, L.				2110275	2110274	
	0.2	2	11341-461-750	KURBELGEMAEUSEDECKEL, L.		1	1			
	0.6	3	11395-425-000	DICHTUNG, L. SEITENDECKEL	1	1	1	1	1	
	0.1	3	30220-438-154	ZUENDVERSTELLER KOMPL. (TCVD)	1					
			30220-438-164	ZUENDVERSTELLER KOMPL. (TOVD)	1			2102237	2102236	
		4	30228-425-010	NABE, STEUERUNG	1	1	1	1	1	
		5	30300-438-154	IMPULSGENERATOR KOMPL. (TOVD)	1	1	1	1	1	
	6	30371-425-000	DECKEL, KONTAKT	1						
		30371-425-010	DECKFL., KONTAKT	1			2110275	2110274		
	7	30372-425-000	DICHTUNG, KONTAKTDECKEL	1	1	1	1	1		
	8	32116-425-000	FESTSTELLPLATTE, IMPULSGEBER-SCHNUR	1	1	1	1	1		



D 8

E-10

Left cover - Advincer

Couvercle gauche - Avance

Linker Deckel - Zündversteller

Cubierta izquierda - Avanzador

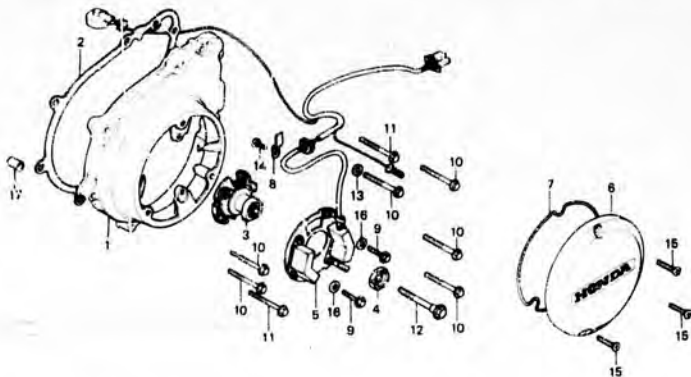

8438-3A

Wartungspunkt	AP	Ref. Nr.	Teile-Nr.	Beschreibung	Menge C8900				Serien.-Nr.	Gebiets-Code
					Fz	Fa	Fz Fa	Fc F2c		
		9	90014-415-000	FLANSCHENSCHRAUBE, 6X14	2					
		10	96000-06014-00	FLANSCHENSCHRAUBE, 6X14	2	2	2	2	2	
		10	90005-415-000	FLANSCHENSCHRAUBE, 6X32	6					
			96000-06032-00	FLANSCHENSCHRAUBE, 6X32	6	6	6	6	6	
		11	90007-428-000	FLANSCHENSCHRAUBE, 6X40	2					
			96000-06040-00	FLANSCHENSCHRAUBE, 6X40	2	2	2	2	2	
		12	90032-425-000	FLANSCHENSCHRAUBE, 8X64	1					
			90032-425-010	FLANSCHENSCHRAUBE, 8X62	1					
		13	90425-100-000	SCHLEIBE, 11MM		1	1	1	1	2012972
		14	92000-06012	SCHRAUBE, HEX., 6X12				1	1	2012971
		15	93700-05025-0A	OVALSCHRAUBE, 3X25	1	1	1	1	1	
			93700-05025	OVALSCHRAUBE, 6X25	3					
						3	3	3	3	2110275
		16	94101-04000	GLATTE SCHEIBE, 6MM	2	2	2	2	2	
		17	94301-08140	PASSTIFT A, 8X14	2	2	2	2	2	



E-11

Starter motor

Moteur démarrage

Anlasser motor

Motor de arranque

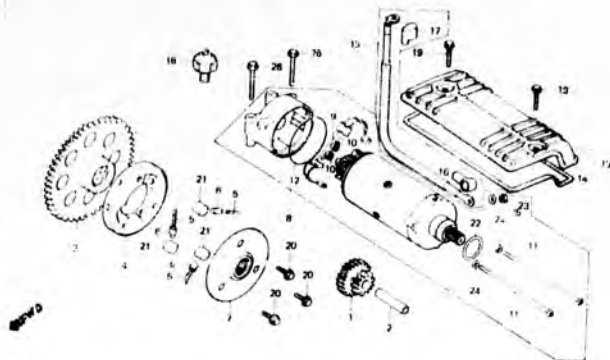

B461 - GA

Wartungspunkt	AP	Ref. Nr.	Teile-Nr.	Beschreibung	Menge					Serien-Nr.	Gebiets-Code
					Fz	Fa	Fb	Fc	F2c		
REDUKTIONSZAHNRAD, ANLASSER MOTOR KOMPL., ANLASSER KABEL, ANLASSERMOTOR	0.4	1	28101-425-000	REDUKTIONSZAHNRAD, ANLASSER WELLE, ANLASSERREDUKTIONSZAHNRAD	1	1	1	1	1		
ZAHNRAD KOMPL., ANLASSERKUPPLUNG	0.5	3	28110-425-000	ZAHNRAD KOMPL., ANLASSERKUPPLUNG (75T)	1					2014331	
FEDER, ANLASSERKUPPLUNGSROLLE			28110-425-01c	ZAHNRAD KOMPL., ANLASSERKUPPLUNG (75T)	1					2014332	
AUSSENTEIL KOMPL., ANLASSERKUPPLUNG	0.6	4	28120-425-000	AUSSENTEIL KOMPL., ANLASSERKUPPLUNG	1	1	1	1	1		
EINSCHL. DAZUGEHÖRIGER TEIL		5	28125-516-030	FEDER, ANLASSERKUPPLUNGSROLLE	3	3	3	3	3		
DECKEL KOMPL., ANLASSMOTOR	0.1	6	28126-516-020	KAPPE, ANLASSERKUPPLUNGSROLLENFEDER	3	3	3	3	3		
DELDRUCKSCHALTER KOMPL., ANLASSER	0.2	7	28130-425-000	ANTRIEBSFLANSCH KOMPL., ANLASSER	1	1	1	1	1		
		8	31200-438-008	MOTOR KOMPL., ANLASSER	1	1	1	1	1		
		9	31201-292-158	KOHLENBUEPSTE SATZ	1	1	1	1	1		
		10	31204-292-158	FEDER, KOHLENBUEPSTE	2	2	2	2	2		

D 10

E-11

Starter motor

Moteur démarrage

Anlassermotor

Motor de arranque

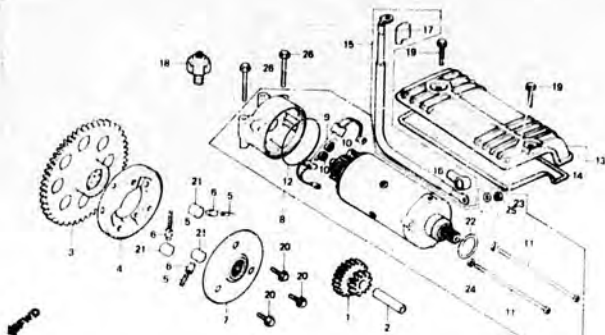

B461-4A

Wartungspunkt	AP	Ref. Nr.	Teile-Nr.	Beschreibung	Menge				Serien-Nr.	Gebiets-Code
					Fz	FA	Fa	Fz		
		11	31205-413-780	SCHRAUBE, ANLASSERMOTORDECKEL	2	2	2	2	2	
		12	31206-286-158	O-RING	1	1	1	1	1	
		13	31280-425-000	DECKEL KOMPL., ANLASSMOTOR	1	1	1	1		
		14	31280-438-670	DECKEL KOMPL., ANLASSMOTOR					1	1
		14	31282-425-300	DICHTUNG, ANLASSMOTORDECKEL	1	1	1	1	1	1
		15	32402-425-000	KABEL, ANLASSERMOTOR	1	1	1	1	1	1
		16	32411-253-000	DECKEL, ANLASSERMOTORELHME	1	1	1	1	1	1
		17	32416-425-000	DECKEL B, MAGNETSCHALTER	1	1	1	1	1	1
		18	35500-333-014	GELEDRUCKSCHALTER KOMPL. (ND)	1	1	1	1	1	1
		19	9000E-413-000	FLANSCHENSCHRAUBE, 6X18	2					
			96000-06018-00	FLANSCHENSCHRAUBE, 6X18	2					
						2				2107965

D 11

E-11

Starter motor

Moteur démarrage

Anlassermotor

Motor de arranque

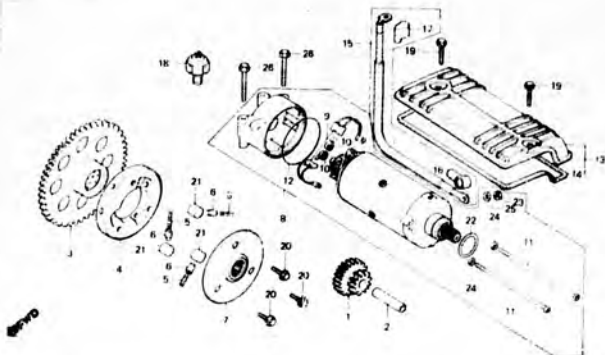

9461-4A

Wartungspunkt	AP	Ref. Nr.	Teile-Nr.	Beschreibung	Menge					Serien-Nr.	Gebiets-Code
					Fz	Fa	Fb	Fz	Fc		
			9600-06012-00	FLANSCHSCHRAUBE, 6X12	2						2107966
		20	90022-425-000	FLANSCHSCHRAUBE, 8X16	3	3	3	3	3	3	
		21	91101-516-000	ROLLE, 15X13	3	3	3	3	3	3	
		22	91309-300-000	O-RING, 24,4X3,1	1	1	1	1	1	1	
		23	94002-06000	MUTTER, HEX., 6MM	1	1	1	1	1	1	
		24	94111-03000	FEDERRING, 5MM	2	2	2	2	2	2	
		25	94111-06000	FEDERRING, 6MM	1	1	1	1	1	1	
		26	95706-06060-00	FLANSCHSCHRAUBE, 6X60	2	2	2	2	2	2	

D 12

E-12

Left crankcase cover - Oil pump

Couvercle de carter moteur gauche -  
Pompe à huile

Linker Kurbelgehäusedeckel -  
Ölpumpe

Cubierta de cárter de motor izquierdo -  
Bomba de aceite

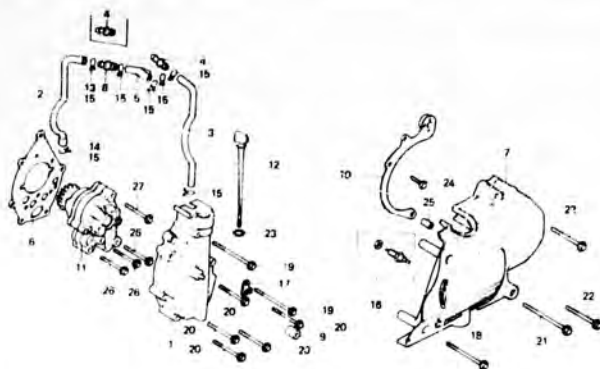

9436-41

Wartungspunkt	AP	Ref. Nr.	Teile-Nr.	Beschreibung	Menge					Serien-Nr.	Gebiets-Code
					Ff	Fa	Fb	Fc	F2c		
DECKEL KOMPL., OELPUMPE ENTLUEFTUNGSSCHLAUCH, R.	0.4	1	11350-425-000	DECKEL KOMPL., OELPUMPE	1	1	1	1		2104808	2104807
	0.2		11350-438-670	DECKEL KOMPL., OELPUMPE				1	1		
SEITENDECKEL, L.		2	11355-425-000	ENTLUEFTUNGSSCHLAUCH, R.	1	1					
SCHUTZBLECH, GEMAEUSE			11355-MA4-670	ENTLUEFTUNGSSCHLAUCH, R.			1	1	1		
LEERLAUFSCHALTER KOMPL., ENTLUEFTUNGSSCHLAUCH, L.	0.3	3	11356-425-000	ENTLUEFTUNGSSCHLAUCH, L.	1						
OELPUMPE KOMPL.	0.5		11356-425-010	ENTLUEFTUNGSSCHLAUCH, L.		1					
		4	11357-425-000	VERBINDUNG, SCHLAUCH	2	2	1	1	1		
		5	11358-425-000	VERBINDUNG,	1	1	1	1	1		
		6	11359-425-000	DICHTUNG, OELPUMPENDECKEL	1						
			11359-425-020	DICHTUNG, OELPUMPENDECKEL		1					
						1				2100008	2100007
		7	11361-438-000	SEITENDECKEL, L.	1	1	1	1	1		
			11361-438-670	SEITENDECKEL, L.		1	1	1	1		
		8	11362-MA4-670	VERBINDUNG, R. SCHLAUCH		1	1	1	1		

D 13

E-12

Left crankcase cover - Oil pump

Couvercle de carter moteur gauche -  
Pompe à huile

Linker Kurbelgehäusedeckel -  
Ölpumpe

Cubierta de cárter de motor izquierdo -  
Bomba de aceite

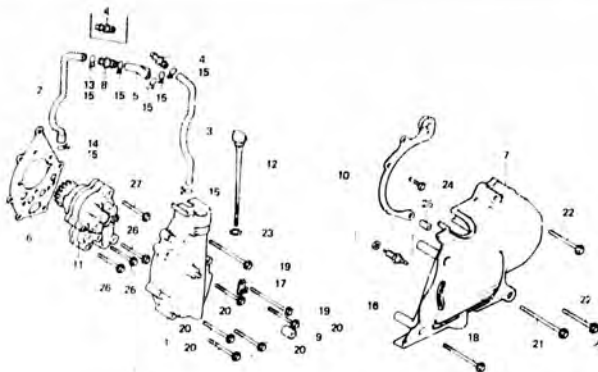

B438 - 1

Wartungspunkt	AP	Ref. Nr.	Teile-Nr.	Beschreibung	Menge				Serien-Nr.	Gebiets-Code
					Fz	Fa	Fa F2a	Fc F2c		
		9	11364-425-000	BEFESTIGUNGSGUMMI, L. SEITENDECKEL	1	1	1	1	1	
		10	11615-438-000	SCHUTZBLECH, GEHÄUSE	1	1	1	1	1	
			11615-438-670	SCHUTZBLECH, GEHÄUSE					1	1
		11	15100-438-000	ÖLPUMPE KOMPL.	1					
			15100-438-003	ÖLPUMPE KOMPL.		1				
									2105175	2105104
		12	15650-425-000	ÖELMESSTAB	1	1	1	1	1	1
		13	1570-634-000	KLEMME, ÖELABLAUSSCHLAUCH	1	1	1	1	1	1
		14	15771-551-000	KLEMME, ÖELABLAUSSCHLAUCH			1	1	1	1
		15	17316-611-000	KLEMME, ENTLUEFTUNGSSCHLAUCH	7	7	5	5	5	5
		16	35600-425-003	LEERLAUFSCHALTER KOMPL.	1	1	1	1	1	1
		17	35610-425-000	KLEMME, LEERLAUFSCHALTERSCHRUR	1	1	1	1	1	1
		18	90002-425-000	FLANSCHENSCHRAUBE, 6X55	1					
			96000-06055-00	FLANSCHENSCHRAUBE, 6X55	1	1	1	1	1	1

D 14

E-12

Left crankcase cover - Oil pump

Couvercle de carter moteur gauche -  
Pompe à huile

Linker Kurbelgehäusedeckel -  
Ölpumpe

Cubierta de cárter de motor izquierdo -  
Bomba de aceite

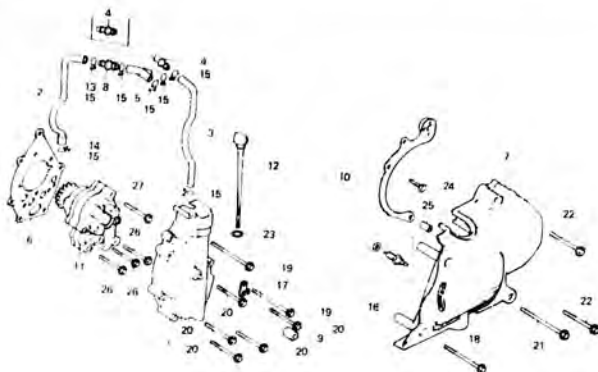

B4301-21

Wartungspunkt	AP	Ref. Nr.	Teile-Nr.	Beschreibung	Menge					Serien-Nr.	Gebiets-Code
					Fz	Fx	Fz	Fc	F2c		
		19	90005-425-000	FLANSCHENSCHRAUBE, 6x65 96000-06065-00	2						
		20	96000-06065-00	FLANSCHENSCHRAUBE, 6x65	2	2	2	2	2	2	
			90007-413-000	FLANSCHENSCHRAUBE, 6x35 96000-06035-00	5						
			96000-06035-00	FLANSCHENSCHRAUBE, 6x35	5	5	5	5	5	5	
		21	90007-425-000	FLANSCHENSCHRAUBE, 6x70	1						
			96000-06070-00	FLANSCHENSCHRAUBE, 6x70	1	1	1	1	1	1	
		22	90007-428-000	FLANSCHENSCHRAUBE, 6x40 96000-06040-00	2						
			96000-06040-00	FLANSCHENSCHRAUBE, 6x40	2	2	2	2	2	2	
		23	91301-230-000	O-RING, 22X3,0	1	1	1	1	1	1	
		24	92000-06016	SCHRAUBE, HEX., 6X16	1	1	1	1	1	1	
		25	94301-06140	PASSTIFT A, 8X14	1	1	1	1	1	1	
		26	95700-06045-00	FLANSCHENSCHRAUBE, 6x45	1	3	3	3	3	3	
		27	95700-06050-00	FLANSCHENSCHRAUBE, 6x50	1	1	1	1	1	1	

D 15

E-13

Oil filter • Oil pan

Filtre à huile • Carter

Ölfiter • Ölwanne

Filtro de aceite • Cáster del aceite

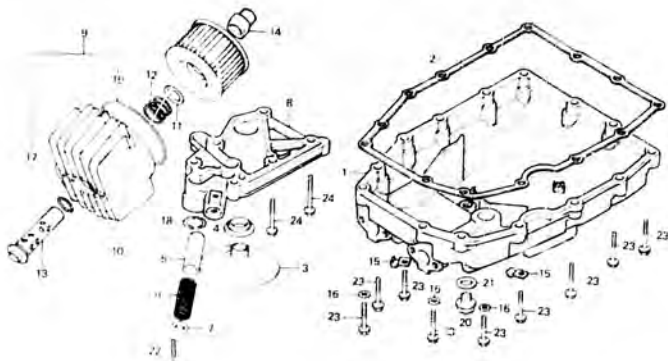

843E-5

Wartungspunkt	AP	Ref. Nr.	Teile-Nr.	Beschreibung	Menge						Serien-Nr.	Gebiets-Code
					Fz	Fa	Fm	Fz	Fc	F2c		
DELWANNE	0.9	1	11210-438-000	DELWANNE	1	1	1	1				
DICHTUNG, DELWANNE	0.8	2	11398-425-000	DELWANNE	1	1	1	1	1			
DELSIEB		2	11398-425-000	DICHTUNG, DELWANNE	1	1	1	1	1			
EINSCHL. DAZUGEHÖRIGER TEIL		3	15153-425-000	DELSIEB	1	1	1	1	1			
ENTLASTUNGSVENTIL, DELDRUCK	1.0	4	15154-425-000	DICHTUNG, DELSIEB	1	1	1	1	1			
KÖRPER, DELPFAD		5	15231-634-010	ENTLASTUNGSVENTIL, DELDRUCK	1	1	7	1	1	1		
EINSCHL. DAZUGEHÖRIGER TEIL	C.2	6	15232-438-000	ENTLASTUNGSVENTILFEDER	1	1	1	1	1	1		
		7	15233-634-000	FEDESITZ, ENTLASTUNGSVENTIL	1	1	1	1	1	1		
		8	15311-438-000	KÖRPER, DELPFAD	1							
			15311-438-010	KÖRPER, DELPFAD	1						2105105	2105104
		9	19410-42L-000	EINSATZ SATZ, DELFILTER	1	1	1	1	1	1		
		10	19411-422-000	GEHÄUSE, DELFILTER	1	1	1	1				
			19411-438-670	GEHÄUSE, DELFILTER	1	1	1	1		1		



D 16

E-13

Oil filter - Oil pan

Fitre à huile - Carter

Ölfiter - Ölwanne

Filtro de aceite - Cáster del aceite

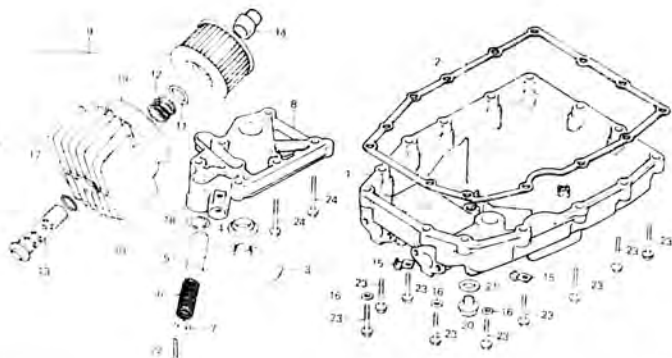

Wartunespunkt	AP	Ref. Nr.	Teile-Nr.	Beschreibung	Menge				Serien-Nr	Gebiets-Code
					F2	Fa	Fb F26	Fc F2c		
		11	15414-300-000	FEDERSITZ, DELFILTER	1	1	1	1	1	1
		12	15415-300-000	HALTEFEDER, DELFITEREINSATZ	1	1	1	1	1	1
		13	15420-300-010	MITTELSCHRAUBE, DELFILTER	1	1	1	1	1	1
		14	15422-425-010	NABE, DELFILTER	1	1	1	1	1	1
		15	32900-438-000	KLEMME, SCHNUR	2	2	2	2	2	2
		16	90441-706-000	DICHTSCHEIBE, 6MM	3	3	3	3	3	3
		17	91302-377-000	O-RING, 15X2,5	1	1	1	1	1	1
		18	91306-634-000	O-RING, 17X3,5MM	1	1	1	1	1	1
		19	91316-300-003	O-RING, 89X4,5	1	1	1	1	1	1
		20	92800-14000	ABLASSCHRAUBE, 14MM	1	1	1	1	1	1
		21	94109-14000	SCHEIBE, ABLASSCHRAUBE, 14MM	1	1	1	1	1	1
		22	94201-30300	SPLINT, 3,0X30	1	1	1	1	1	1
		23	95700-06028-00	FLANSCHENSCHRAUBE, 6X28	14	14	14	14	14	14
		24	95700-06032-00	FLANSCHENSCHRAUBE, 6X32	6	6	6	6	6	6

**E 1**

**E-14**

Crankcase

Carter moteur

Kurbelgehäuse

Carter de motor

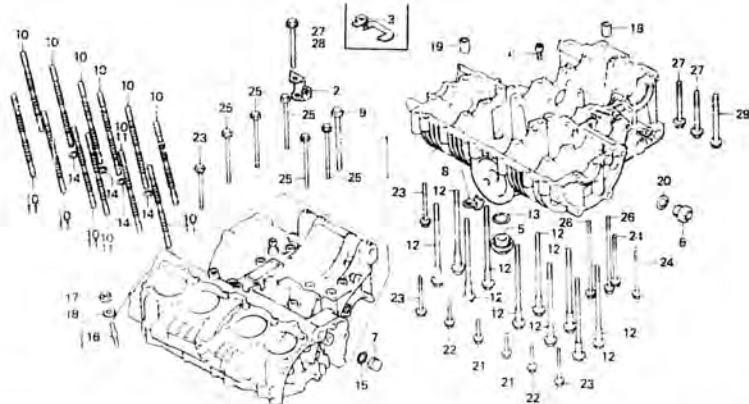

9-19-73

Wartungspunkt	AP	Ref. Nr.	Teile-Nr.	Beschreibung	Menge (CRANK)				Serien-Nr.	Gebets-Code
					Fz	FA	Fa	F2c		
KURBELGEHÄUSE SATZ STENDBOLZEN, 10x230,5 (JEWELNS 0,1 DAUZAÄHLEN,)	* 8.9 (* 8.2) * 5.1 (* 5.4)	1	11000-425-310	KURBELGEHÄUSE SATZ	1					
			11000-438-010	KURBELGEHÄUSE SATZ	1				2100008	2100007
) 1: F2b, F2c TVP		2	11000-MB7-670	KURBELGEHÄUSE SATZ		1	1	1		
		2	11381-438-670	EMPFÄNGER, KUPPLUNG				1	1	
		3	11618-425-000	SCHUTZPLATTE, SCHLAUCH	1	1	1	1		
		4	11520-425-003	DELKONTROLLMÜNDUNG	1	1	1	1	1	1
		5	12361-035-000	KAPPE, VENTILSPIEL- EINSTELLUNGSLOCH	1	1	1	1	1	1
		6	15331-300-000	KAPPE, DELPFAD	1	1	1	1	1	1
		7	15336-393-000	STÖPSEL, DELPFAD	1	1	1	1	1	1
		8	32900-438-000	KLEMME, SCHNUR	1	1	1	1	1	1
		9	90024-425-000	FLY-SCHENK-SCHRAUBE, 8x32	1	1	1	1	1	1
		10	90031-438-003	STENDBOLZEN, 10x230,5 (YOKAI)	17	12	12	12	6	6
		11	90032-438-003	STENDBOLZEN, 10x230,5 (YOKAI)					6	6

E 2

## E-14

Crankcase

Carter moteur

Kurbelgehäuse

Cárter de motor

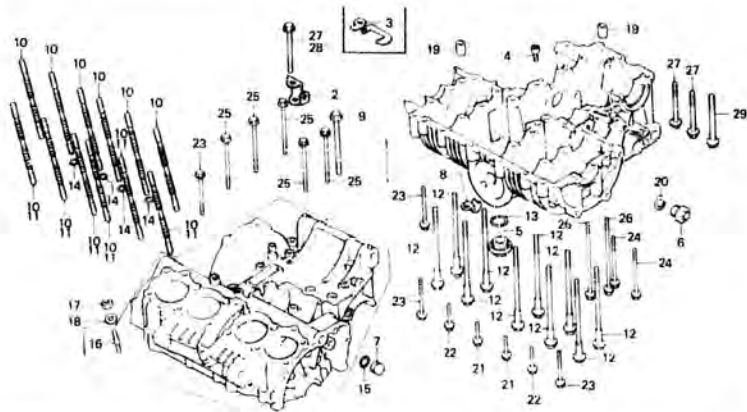

423P 5/6

Wartungspunkt	AP	Ref. Nr.	Teile-Nr.	Beschreibung	Maßstab				Serien-Nr.	Gebiets-Code
					Fz	Fa	Fa 2	Fc F2c		
		12	90042-393-000	BUNDSCHRAUBE, 8X118	10	10	10	10	10	
		13	91302-001-020	O-RING, 30,8MM	1	1	1	1	1	
		14	91305-639-000	O-RING, 9,5X3	4	4	4	4	4	DK, DM, E, ED, G, SA, U
		15	91306-329-000	O-RING, 16X1,9	1	1	1	1	1	2115479 DK, DM, E, ED, G, SA, U
		16	92700-06035	STEBBOLZEN, 6X35	1					
			90028-425-000	STEBBOLZEN, 6X34	1					2105920 2105919
		17	94001-06000	MUTTER, HEX., 6MM	1	1	1	1	1	
		18	94101-05000	GLATTE SCHEIBE, 6MM	1	1	1	1	1	
		19	94301-17160	PASSTIFT A, 1,0X16	2	2	2	2	2	
		20	94608-40000	O-RING, 19,4X2,4	1	1	1	1	1	
		21	95700-06035-00	FLANSCHENSCHRAUBE, 6X35	2	2	2	2	2	
		22	95700-06040-00	FLANSCHENSCHRAUBE, 6X40	2	2	2	2	2	
		23	95700-06050-00	FLANSCHENSCHRAUBE, 6X50	4	4	4	4	4	
		24	95700-06070-00	FLANSCHENSCHRAUBE, 6X70	2	2	2	2	2	
		25	95700-06080-00	FLANSCHENSCHRAUBE, 6X80	5	5	5	5	5	

**E 3**

**E-14**

Crankcase

Carter moteur

Kurbelgehäuse

Cárter de motor

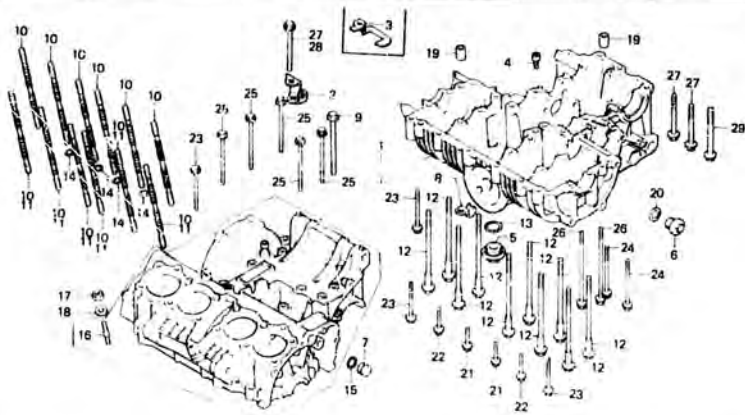

8596-6A

Wartungspunkt	AP	Ref. Nr.	Teile-Nr.	Beschreibung	Menge				Serien-Nr.	Gebiets-Code
					Fz	Fa	Fa Fz	Fc Fz		
		26	95700-06110-00	FLANSCHENSCHRAUBE, 6X110	2	2	2	2	2	
		27	95700-08060-00	FLANSCHENSCHRAUBE, 8X60	3	3	3	2	2	
		28	95700-08065-00	FLANSCHENSCHRAUBE, 8X65					1	1
		29	95723-10065-00	FLANSCHENSCHRAUBE, 10X65	1	1	1	1	1	1